



HAL
open science

Application of ultra/nano filtration membrane in uranium rejection from fresh and salt waters

C Xing, B Bernicot, Guilhem Arrachart, S Pellet-Rostaing

► To cite this version:

C Xing, B Bernicot, Guilhem Arrachart, S Pellet-Rostaing. Application of ultra/nano filtration membrane in uranium rejection from fresh and salt waters. *Separation and Purification Technology*, 2023, 314, pp.123543. 10.1016/j.seppur.2023.123543 . hal-04394862

HAL Id: hal-04394862

<https://hal.umontpellier.fr/hal-04394862>

Submitted on 15 Jan 2024

HAL is a multi-disciplinary open access archive for the deposit and dissemination of scientific research documents, whether they are published or not. The documents may come from teaching and research institutions in France or abroad, or from public or private research centers.

L'archive ouverte pluridisciplinaire **HAL**, est destinée au dépôt et à la diffusion de documents scientifiques de niveau recherche, publiés ou non, émanant des établissements d'enseignement et de recherche français ou étrangers, des laboratoires publics ou privés.

Application of ultra/nano filtration membrane in uranium rejection from fresh and salt waters

C.Xing, B. Bernicot, G. Arrachart*, S. Pellet-Rostaing*

ICSM, CEA, ENSCM, CNRS, Univ Montpellier, Marcoule, France

guilhem.arrachart@umontpellier.fr ; stephane.pellet-rostaing@cea.fr

Abstract

Ultra/nano filtration (UF/NF) is widely explored for ion separation in aqueous solution, which can be effective, by the electric and steric effect. The uranium extraction from unconventional resources such as seawaters constitutes an important secondary source of uranium for nuclear fuel production. Commercial inorganic UF/NF membranes of different molecular weight cut-off (MWCO) have been investigated for separation of uranium from other salts in natural or synthetic seawaters and freshwaters. Various physical–chemical parameters, such as pH value, temperature, pressure, salt concentration, solution composition, are studied for their influence on different metal (U, Ca, Mg, Na, etc.) rejections. Speciation diagrams implemented with PHREEQC software have helped to understand the rejection mechanism. The pH value and salt concentration are two key parameters determining rejection since the high salinity shields the electric rejection. Experimental conditions for an efficient separation of U to Na was determined to concentrate the uranium. Filtration experiments with natural or synthetic seawaters and freshwaters show that the presence of CaCl₂ or MgCl₂ hinders the reject of every specie including U (VI). Three hypotheses based on the filtration experiments and theoretical simulations have been proposed to explain this phenomenon. This study examines the membrane electric effect to reject solution species and demonstrate the potential for uranium concentration by UF/NF.

1. Introduction

Uranium is mainly used as fuel in nuclear power plants to produce electricity, given the increase in energy needs, the demand for uranium will therefore also increase. Whether or not it is possible to obtain sufficient fuel will become a key factor in the sustainable development of nuclear industry. To ensure the long-term development of nuclear power production, it is crucial to exploit nonconventional uranium resources, such as uranium in seawater. 71% of the surface of earth is covered by oceans and seas, there are some 50 quadrillion tons of minerals and metals dissolved in all the world's seas and oceans [1]. Thus uranium, calcium, magnesium, potassium, sodium represents a much larger amount of storage compared to the land and underground resources [2]. Uranium can be found in seawater at a concentration of 3.3 µg.L⁻¹, forming highly stable Ca-UO₂-CO₃ and Mg-UO₂-CO₃ species [3,4]. Although dilute, this equates to an about 4.5 billion tons of uranium, about 1000 times more than is available from conventional sources such as earth ores. These reserves greater than the terrestrial uranium reserves, offer a substantial potential source of nuclear fuel. Therefore, uranium in seawater will be a near-limitless resource for nuclear fuel in the future, and its recovery will avoid the deleterious environment impact of terrestrial mining. However, efficient and selective extraction of uranium from seawater is particularly challenging because of the complex solution chemistry in seawater including high salt concentration (average salinity around 35 g.L⁻¹ mainly due to NaCl), high

carbonate concentration, basic pH (7.5–8.5), temperature (5–35 °C), low uranium concentration (~3.3 µg. L⁻¹), and other metal ions at similar or higher concentrations. Although there are many difficulties to overcome, the recovery of U from seawater is one of the most promising solutions given the importance of this resource [1,2,5,6].

To achieve the goal to concentrate U from seawaters, various methods have already been evaluated. Many materials with specific functions have been investigated, particularly including recent developments in inorganic materials, polymer adsorbents and related research belong to amidoxime, and nanostructured materials such as metal-organic frameworks, porous-organic polymers, and mesoporous carbons [7]. Among them, amidoxime-based materials serve as one of the most promising candidates and are the main tool used for uranium extraction from aqueous systems owing to their special affinity for uranium [8-10]. More recently, new methods based on the use of DNA-based uranium extraction hydrogel adsorbent [11], hydrogel-like spideroin-based protein fiber [12] and biofouling-resistant polymeric peptide materials [13] shows interesting perspectives in the context of uranium recovery from seawaters. Compared to these methods, membrane technologies are known to be flexible, automatable and can work continuously. Moreover, extraction, separation or purification takes place through purely physical without phase change [14]. Membrane separation processes have been used for several years to concentrate or fractionate suspended particles and dissolved substances. Reverse osmosis (RO), now in widespread use to prepare irrigation water from briny waters, and ultrafiltration (UF) both constitute a valuable aid for the fractionation and concentration of colloidal substances. Nanofiltration (NF) membranes have intermediate molecular weight cut-offs (MWCOS) between UF and RO membranes. NF using organic or inorganic membranes has been found to be useful recently for recycling and recovery metals from urban mine [15], from seawater desalination brine [16], from industrial wastewater [17], selectively remove of minor actinides from lanthanides [18-23], removing uranium from drinking water [24] and from seawater [25]. Some renewable energy powered membrane technologies have been investigated for water treatment and ions separation [26-29]. Ultra/nano filtration process using inorganic membranes can concentrate multivalent metal ions by rejection attributed to a combination of various mechanism including steric, electric, Donnan, dielectric and transport effects [30]. Steric effect and electric effect are two major factors that affect the rejection. A chemical species will be retained by the membrane if its size is larger than that of the pores [18]. In addition to size exclusion, charged species in solution can be rejected by electrical interactions with charges in the membrane material. Membranes in contact with an aqueous solution acquire an electric charge by dissociation of surface functional groups, adsorption of ions and ionised solutes from the solution. The origin of this charge comes from the ionization of sites on the surface of the membrane generally resulting from the acid-base properties of the surface groups and the ionic strength of the solution. The electrical interactions can take place on the surface of the membrane or through the pore [31]. Therefore, the UF/NF membrane can reject charged solutes of much smaller size than the dimensions of the pores. This Donnan exclusion mechanism can be particularly used to remove ions from waters and to separate them according to their ionic valences [32]. Indeed, surface groups are strongly influenced by the pH of the contacting solution since the membrane exhibits an IsoElectric Point (IEP) [33]. The IEP is the pH value of the solution for which there are as many positive and negative ions around the surface of the membrane. The surface will be positively charged if the pH is lower than the IEP and conversely, it will be negatively charged if the pH is higher than the IEP. For the ceramic membrane used in this study, the manufacturer provides a value for IEP ≈ 5.5. The purpose of this study is to evaluate the opportunities of inorganic TiO₂/ZrO₂ membranes with a molecular weight cut-off (MWCO) of 1 or 5 kDa for the selective concentration of valuable metal ions, such as U from different water solutions, for example, from seawater. The choice of inorganic membranes is based on its advantages of

amphoteric behaviour, excellent tolerance to wide pH and temperature ranges, outstanding mechanical strength, longer operational lifetime, and lower clogging tendency [34]. First, the influence of various parameters (MWCO, pH, temperature, applied pressure, composition of solutions, ionic strength) to rejections of U and Na have been studied with simple synthetic solutions of uranyl ion or uranyl carbonate complex and sodium. Then, the comparison of the influence of pH to rejections of U, Mg, Ca, Na, and K was studied with the corresponding solutions. Finally, the filtration experiments are performed with synthetic and real seawaters or river waters to see the possibility of separating U from the other competitive species. At the same time, the species distributions of all the solution systems have been simulated using PHREEQC software for a better understanding of the mechanism of interactions of metal cations with the membrane.

2. Experiments

2.1. Materials and methods

Ultra/nano filtration experiments are investigated in a 1 L volumetric reactor filled with synthetic or real solutions. Experiments are performed with a SIVA laboratory-scale membrane system which is illustrated in Fig. 1 with detailed caption. The filtration membrane system consists of three main parts: i) the feed tank, ii) the membrane cell and iii) the pump which pumped the feed solution from the feed tank to reach the membrane cell body. The feed of volume 1 L is maintained at constant composition and volume during each filtration by totally recycling the permeate and the retentate back to feed. Feed solutions are filtered through the membranes in a crossflow mode for minimizing the clogging at the membrane surface. During filtration, the metal ions in the feed are convectively driven to the membrane surface by transmembrane pressure (TMP), thus forming a concentrated polarization boundary layer near the membrane. A feed flowrate of 0.1 m³/h is applied, the pressure is set from 1 to 3 bars. A cooling system is implemented to maintain a constant experiment temperature during the experiment. The pH of the solution is constant during the filtration. Flowmeters and pressure meters monitor the flow rates and pressures of each part of system.

2.2. Filtration experiments

For the filtration experiment, the valves VFA, VFR and VFP are open. The permeate and retentate can be collected at the end of the pipes. For cleaning the membrane, the valves VCA, VCR are open. The circulation pump ensures the circulation of the solution in the system. Rejection of metal ions is evaluated from the retentate and permeate concentration of samples collected during the experiments. The rejection R_i (%) of a substance i is calculated with the following equation (1):

$$R_i(\%) = 100 \times \left(1 - \frac{C_p^i}{C_{Ret}^i} \right) \quad (1)$$

where C_{Ret}^i is the concentration of i in the retentate (flux that has not passed through the pores of the membrane) and C_p^i is the concentration of i in the permeate (corresponding to the flux that has passed through the pores of the membrane). The concentration of retentate can be considered equal to the feed concentration because the flux rate of retentate (0.1 m³/h) is far higher than that of permeate (0.05–0.5 L/h).

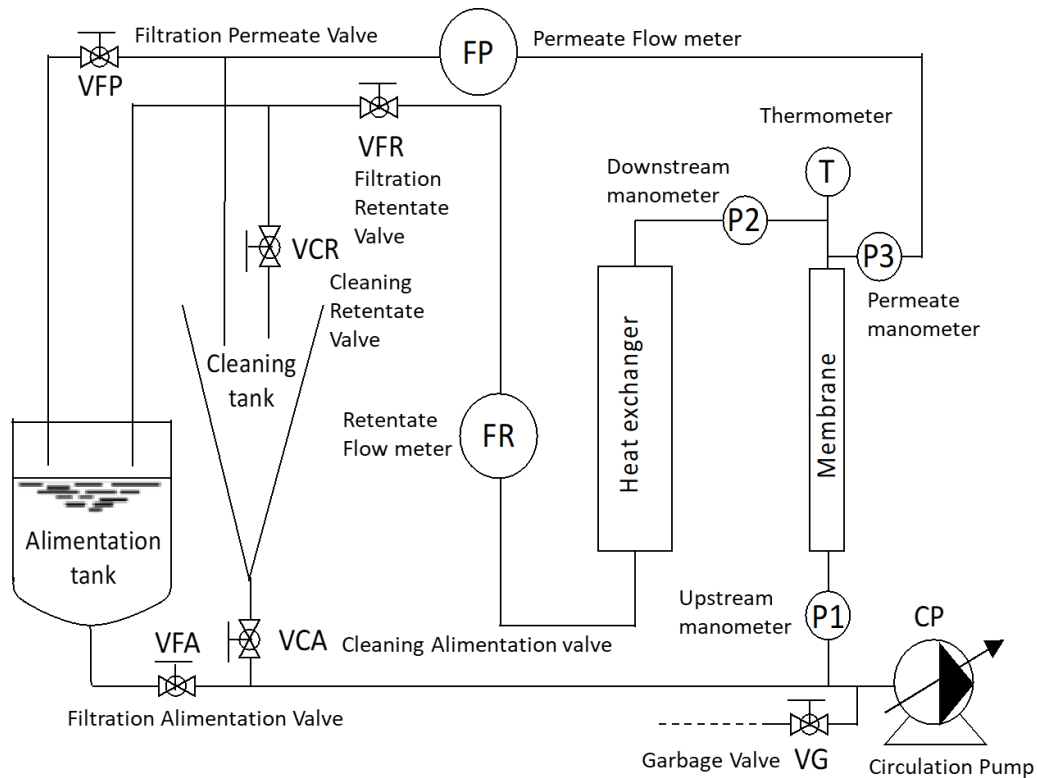

Fig. 1 Schematic representation of the SIVA laboratory-scale membrane filtration system used in this study.

2.3. Membrane

The inorganic filtration membrane used was a multi-layer structure with a TiO₂/ZrO₂ active layer and a tubular channel titanium support (CÉRAMTM - TAMIS INDUSTRIES, Nyons, 26 - France). They consist of several elements. The filter layer is based on a titanium tubular support of a length of 25 cm with an outer diameter of 10 mm. Mono canal membranes are used with a hydrodynamic diameter of 6 mm, allowing the passage of fluid within the hollow portion. The range of MWCO employed varies between 1 and 8 kDa.

2.4. Sample preparation

Synthetic solutions of UO₂²⁺ or uranyl carbonate complex are prepared from 10 g.L⁻¹ uranyl nitrate UO₂(NO₃)₂·6H₂O, in HNO₃ 2%, and NaHCO₃ powder in ultra-pure water (milli-Q water), synthetical grade salts of NaCl, MgCl₂, CaCl₂, KCl, Na₂SO₄, NaHCO₃ are added to corresponding solutions depending on the desired composition. Then, pH of the filtration feed was measured using a pH meter (Metrohm 781 pH meter) and adjusted to the desired value by adding 2 mol.L⁻¹ NaOH or 1 mol.L⁻¹ HCl. Simple synthetic solutions of UO₂²⁺ or uranyl carbonate complex and sodium at different pH values (solution 1: [U] = 8.4 × 10⁻⁵ mol.L⁻¹, [NaHCO₃] = 1 × 10⁻² mol.L⁻¹) are first studied towards varying

physical–chemical parameters (pH, temperature, pressure, MWCO, etc.). Similar synthetic solutions of U and Na were prepared in the same way with NaCl of concentration from 0.017 to 0.6 mol.L⁻¹ in order to evaluate the influence of ionic strength (salt concentration) to rejection. Various solution of U, Na₂SO₄, NaHCO₃, NaCl were studied to estimate the sodium salt type influence on U and Na rejection. According to the composition of seawater, NaCl, MgCl₂, Na₂SO₄, CaCl₂, KCl are the most predominant salts. To follow the rejections of these salts, filtration study was conducted separately on solution of CaCl₂, of MgCl₂, and solution with two salts NaCl and KCl. The influence of the pH to the rejection of Ca is evaluated with the solution of CaCl₂ of 5.00 × 10⁻⁴ mol.L⁻¹ of pH from 3 to 8.25. The influence of the pH to the rejection of Mg was studied with MgCl₂ solutions of 8.23 × 10⁻⁴ mol.L⁻¹ of pH from 3 to 8.25. The influence of the pH to the rejections of Na and K is gauged with the solutions of NaCl (8.69 × 10⁻³ mol.L⁻¹), KCl (5.13 × 10⁻⁴ mol.L⁻¹) from pH 3 to 8.25. Mediterranean seawater (seawater A) and synthetic Baltic seawater doped with U at about 1 mg.L⁻¹ (seawater B) are chosen to represent respectively high salinity seawaters and low salinity seawaters, while Rhone River doped with U (freshwater F) is chosen as an example of freshwaters. Rhone River water was prefiltered by 0.45 μm PVDF Membrane before the NF/UF filtration. The salinity of Baltic seawater doped with U is adjusted to 7.5 g.L⁻¹ [35] composed with the same salts in the Mediterranean seawater. The pH value of seawater B is controlled at 8.2–8.3. The pH value of the river water is measured at values from 8.4 to 8.6. In U-doped river water, the concentration of uranium is fixed at 2 mg.L⁻¹. The possibility to separate U from other cations, which are originally present in such real and synthetic seawater and river waters, was then investigated. The influence of the presence of Ca cation or Mg cation to U rejection was studied with solutions of U, NaHCO₃, MgCl₂, and of U, NaHCO₃, CaCl₂. Finally, the shield effect of CaCl₂ to U rejection was evaluated with the solution of which the concentration of U is fixed at 8.40 × 10⁻⁵ mol.L⁻¹, the concentration of NaHCO₃ is of 1.0 × 10⁻² mol.L⁻¹, and the concentration of CaCl₂ is controlled from 2.16 × 10⁻⁵ to 5.82 × 10⁻⁴ mol.L⁻¹.

2.5. Species distribution by PHREEQC

Speciation diagrams of U in all the solution systems studied are built with the software PHREEQC with database “NEA_TDB_phreeqc_December2020” to predict species distribution in each solution with the aim to highlight a relationship between the filtration electric effect and the solution composition, then to allow to consider the different rejections behaviour in the different solutions. Uranium (VI) carbonate systems are often very complicated because they consist of several different complex ions that are in rapid equilibrium with each other and with aquo ions or hydrolysed species [25]. Examples of speciation diagrams are illustrated in Fig. 2.

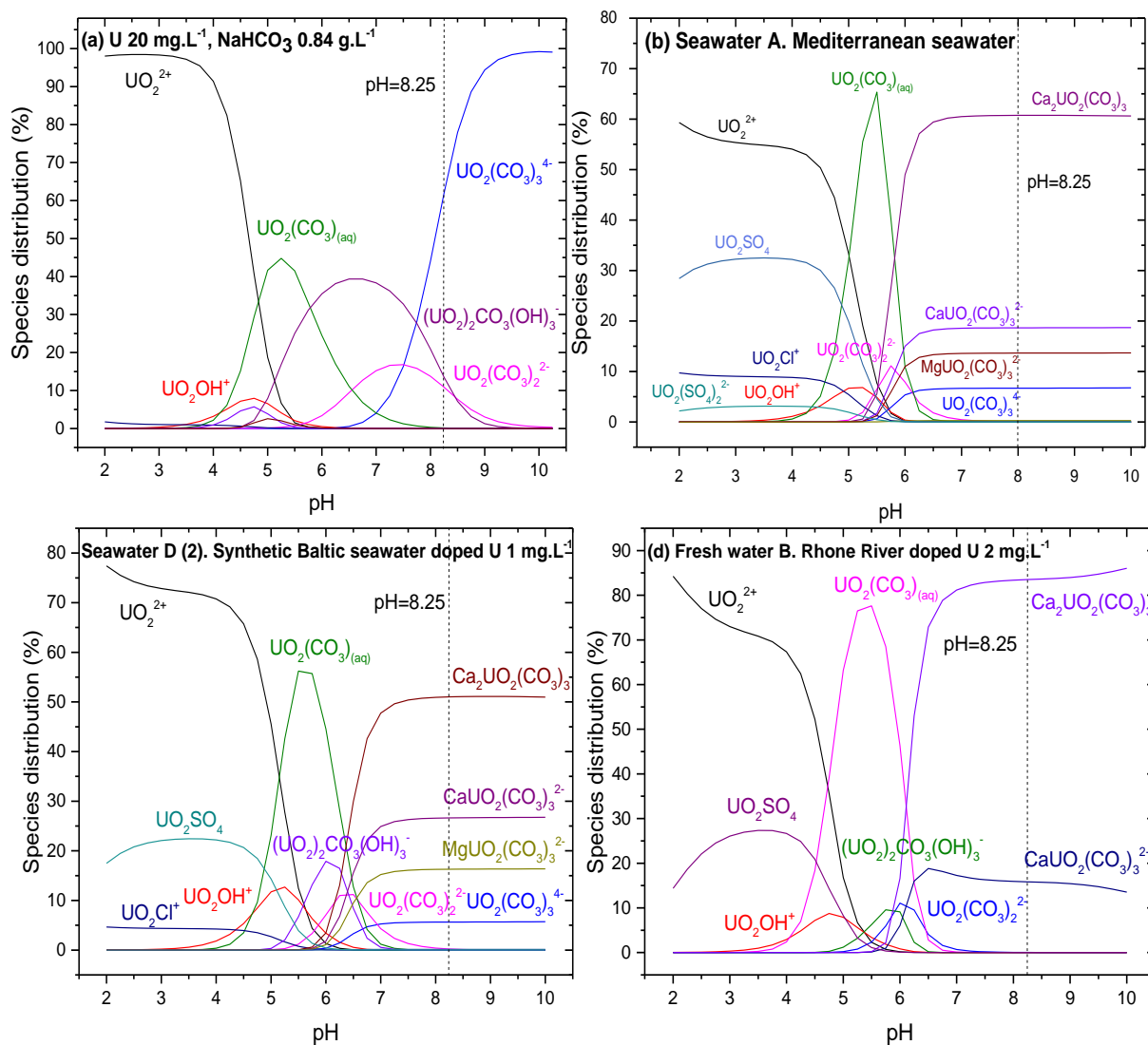

Fig. 2 The species distribution of aqueous U complexes in solution 1, seawater A, seawater S-D (2), fresh water F-B. (a) Solution 1: U 20 mg.L⁻¹, NaHCO₃ 0.84 g.L⁻¹. [U] = 8.40×10⁻² mmol.L⁻¹, [Na] = 1.0×10⁻² mol.L⁻¹, [C] = 1.0×10⁻² mol.L⁻¹. (b) Seawater A: Mediterranean seawater. I = 0.534 mol.L⁻¹. [U] = 1.426×10⁻⁵ mmol.L⁻¹, [Na] = 0.319 mol.L⁻¹, [Mg] = 5.225×10⁻² mol.L⁻¹, [K] = 1.218×10⁻² mol.L⁻¹, [Ca] = 1.19×10⁻² mol.L⁻¹, [Cl] = 0.437 mol.L⁻¹, [C] = 2.388×10⁻³ mol.L⁻¹, [S] = 9.897×10⁻³ mol.L⁻¹. (c) Seawater S-D (2): Synthetic Baltic seawater doped with U. I = 0.135 mol.L⁻¹, [U] = 4.201×10⁻³ mmol.L⁻¹, [Na] = 9.112×10⁻² mol.L⁻¹, [Mg] = 1.034×10⁻² mol.L⁻¹, [K] = 2.57×10⁻³ mol.L⁻¹, [Ca] = 2.72×10⁻³ mol.L⁻¹, [Cl] = 0.115 mol.L⁻¹, [C] = 8.524×10⁻⁴ mol.L⁻¹, [S] = 1.999×10⁻³ mol.L⁻¹. (d) Fresh water F-B: Rhone River doped with U. I = 6.944×10⁻³ mol.L⁻¹, [U] = 8.405×10⁻³ mmol.L⁻¹, [Na] = 5.458×10⁻⁴ mol.L⁻¹, [Mg] = 2.385×10⁻⁴ mol.L⁻¹, [K] = 5.92×10⁻⁵ mol.L⁻¹, [Ca] = 1.693×10⁻³ mol.L⁻¹, [Cl] = 5.841×10⁻⁴ mol.L⁻¹, [C] = 2.753×10⁻³ mol.L⁻¹, [S] = 5.613×10⁻⁴ mol.L⁻¹. Drawn by PHREEQC, based on the formation constants of Ca-UO₂-CO₃, Mg-UO₂-CO₃, NEA TDB database updated in December 2020. Minor U species are not shown.

Fig. 2 (a), (b), (c) and (d) show respectively the species distribution of solution 1, seawater A, seawater B, freshwater F. In solution 1, U is present in the form of UO₂(CO₃)₃⁴⁻, UO₂(CO₃)₂²⁻ and (UO₂)₂CO₃(OH)₃³⁻ at pH 8.25, which are all negative charge species.

The species distribution in the seawater A and B are relatively similar despite the difference in U concentration. In seawater A, NaCl, MgCl₂, Na₂SO₄, CaCl₂ and KCl are the principal salts. At pH 8.25, Ca₂UO₂(CO₃)₃, CaUO₂(CO₃)₃²⁻, MgUO₂(CO₃)₃²⁻ and UO₂(CO₃)₃⁴⁻, representing respectively 60%, 20%, 15% and 5% of proportion, make the composition of U. As for seawater B, Ca₂UO₂(CO₃)₃, CaUO₂(CO₃)₃²⁻, MgUO₂(CO₃)₃²⁻ and UO₂(CO₃)₃⁴⁻, representing respectively 50%, 30%, 15% and 5% of proportion. However, in freshwater F, U is 85% in the form of Ca₂UO₂(CO₃)₃ and 15% in the form of CaUO₂(CO₃)₃²⁻. The more general feature with NF membranes is the separation of salts according to their size and valence. Thus, a high rejection of these highly charged U species can be expected.

2.6. Analytical procedures and error analysis

For doped-U solutions, quantification of U, Na, Ca, Mg, K in simulated seawater was performed with ICP-OES (Inductively Coupled Plasma Optical Emission Spectroscopy, iCAP 7000 Series) with a standard deviation of ± 2%. Each filtration experiment was repeated at least 2 times. Analyte concentrations were determined with respect to calibration standards in dilute nitric acid. The absence of interferences was checked during the analysis. Analysis of uranium in real seawater and in river waters is performed using ICP-MS (Inductively Coupled Plasma Mass Spectrometer, iCAP RQ). Analyte concentrations were determined using matrix-matched calibration. Errors were estimated with ICP measurement calibration, the verification of the mass-balance at each step of the filtration also allows to establish the uncertainty on the process. The detail for the error estimation is provided in the supporting information.

2.7. Evaluation of membrane performance

The filtration experiment was proceeded in a closed filtration system. Closed filtration system is defined by the constant feed volume during the whole filtration process. The filtration is conducted with 1 L of feed solution. During the whole process, the retentate and the permeate go back to the feed, keeping the almost constant volume. The recuperation of permeate and retentate, both about 10 mL (relatively negligible to 1 L), is carried out about each 30 min to evaluate the rejections towards ICP measurement. The experiments were repeated several times to improve the reliability of the results. Closed filtrations are conducted to evaluate the influence of various physical–chemical parameters (pH, MWCO, pressure, temperature, sodium salt types, the solution salinity, solution composition) to filtration performance. Concentration of each element in solution was measured by ICP-OES and ICP-MS.

3. Results and discussion

3.1. Uranium and sodium rejections

3.1.1. Effect of the pH, MWCO, temperature and pressure

Various parameters (pH, temperature, Pressure, MWCO) have been investigated to study the possibility of U/Na separation by membrane filtration, for this purpose a solution consisting of U(VI) at 8.40×10^{-5} mol/L and NaHCO_3 at 1.0×10^{-2} mol/L was studied. The effect of pH, ranging from 2.3 to 8.25, on U and Na rejection was studied using 5 kDa membrane, with an applied pressure of 3 bars, with temperature around 22 ± 2 °C, a retentate flux of $0.1 \text{ m}^3/\text{h}$. The rejections of U and Na according to pH have similar profiles as depicted in Fig. 3.

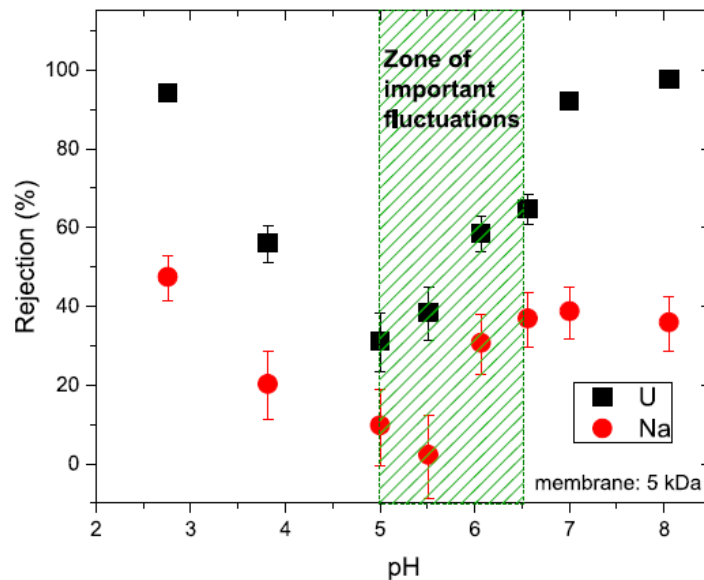

Fig. 3. Rejections of U and Na as a function of pressure with solutions of pH 8.25; Feed solution: solution 1, pH varies from 2.3 to 8.25.

U and Na are both rejected driven by electrical repulsion. Na rejection decreases from 50% at pH 3 to 0% at pH 5.5 and increases to 35% at pH 8.25. The separation of U to Na can be realized with the optimal efficiency at pH 8.25 or 3 in solution containing U and NaHCO_3 . The minimum rejection was found at pH 5.5 that corresponds to the IEP of ceramic membrane. However, the rejection of U decreases from 95% at pH 3 to its minimum value 30% at pH 5, then it increases from 30% to 100% while pH increasing from 3 to 8.25. According to Donnan effect, the more pH value is close to IEP, the weaker is the electric repulsion. This outline illustrates that the electric effect contributes to the species-membrane interaction and is explained by Donnan effect (Equation (2)) [36,37].

$$\left(\frac{[A]_m}{[A]_s}\right)^{1/Z_a} = \left(\frac{[C]_s}{[C]_m}\right)^{1/Z_c} \quad (2)$$

where $[A]_m$ and $[C]_m$ represents the concentrations of the anion and the cation at the surface of the membrane, $[A]_s$ and $[C]_s$ their concentrations within the solution. Z_a and Z_c represent the valences of anion and cation respectively. The higher the charge of the co-ion to the membrane, the higher is the rejection. On the other hand, the higher the charge of the counterion, the lower is the rejection of the co-ion [38-41]. When the pH is high in solution, $\left(\frac{[H^+]_s}{[H^+]_m}\right)^{1/1}$ tends to 0, $\left(\frac{[U(VI)^{n-}]_m}{[U(VI)^{n-}]_s}\right)^{1/Z_U}$ also tends to 0, in the membrane the concentration of negatively charged U species tend to 0, the co-ions cannot practically penetrate the membrane. It is the mathematical translation of Donnan exclusion principle.

As observed, U is more rejected than Na whatever the pH. From pH 3 to 5, U is in the form of UO_2^{2+} , having larger charge than Na^+ , as co-ions of the positively charged membrane, both are rejected.

According to Donnan relation, $\left(\frac{[UO_2^{2+}]_m}{[UO_2^{2+}]_s}\right)^{1/Z_U} = \left(\frac{[OH^-]_s}{[OH^-]_m}\right)^{1/Z_{OH^-}}$ $\left(\frac{[Na^+]_m}{[Na^+]_s}\right)^{1/Z_{Na^+}} = \left(\frac{[OH^-]_s}{[OH^-]_m}\right)^{1/Z_{OH^-}}$.

When pH is low, $\frac{[OH^-]_s}{[OH^-]_m}$ tends to negligible. As a result, $\left(\frac{[UO_2^{2+}]_m}{[UO_2^{2+}]_s}\right)^{1/Z_U}$ and $\left(\frac{[Na^+]_m}{[Na^+]_s}\right)^{1/Z_{Na^+}}$ also tends

to 0. $Z_c(UO_2^{2+}) = 2$, $Z_c(Na^+) = 1$, $Z_c(OH^-) = 1$. If $\frac{[OH^-]_s}{[OH^-]_m}$ is 0.01, then $\frac{[UO_2^{2+}]_m}{[UO_2^{2+}]_s}$ is 0.0001. $\frac{[Na^+]_m}{[Na^+]_s}$ is 0.01. U is

thus 100 times more rejected than Na. While pH is from 5 to 8.25, the proportion of negatively charged U species $UO_2(CO_3)_2^{4-}$, $UO_2(CO_3)_2^{2-}$ and $(UO_2)_2CO_3(OH)^-$ increases with the increase of pH value. At the same time, the negative charge on the membrane surface increases. Clearly, according to Donnan effect, U in the form of carbonate complex is largely rejected and reaches the maximum rejection around pH 8. However, Na^+ , as the counterion of membrane, should pass through the membrane freely. As a result, it has smaller rejection than U. The overall salt rejection is heavily dependent on the rejection of co-ions. Therefore, a higher Donnan potential with the presence of negatively charged uranyl carbonate complex leads to an increase overall salt rejection of the membrane [40,42]. That explains that the Na^+ rejection is not 0% even that the global membrane charge is negative. The observed trends are in good agreement with the membrane IEP. The given IEP of industrial membrane supplier is 5.5, corresponding to the pH of minimum Na^+ rejection. The minimum rejection of U is found at pH 5, not at 5.5. At pH 5.5, green-yellow precipitation was observed in the retentate solutions. This could be the precipitation of UO_2CO_3 . According to the speciation diagram, the dominant species in solution of U and $NaHCO_3$ at pH 5.5 is $UO_2CO_3(aq)$, this specie could be precipitated when its maximum solubility is reached. According to PHREEQC calculation, when pH is from 4.75 to 6.0, the saturation index is superior to 0 ($> +0.31$ when pH is from 5 to 5.5). Concerning a water solution containing $CaCO_3$, when the saturation index is high enough ($+0.31$ or higher), water has too much

CaCO₃ in it. Water must precipitate CaCO₃ to get itself back under + 0.30 and into the balanced range. As a result, the abnormal high rejection of U observed at pH 5.5 is due to the UO₂CO₃ precipitation since U is rejected by the steric effect.

Depending on the pH, different filtration time is required for the filtration to reach the steady state (See Table S1 and Fig. S1.1 in the supporting information). When solution pH value is 5, 5.5, 6 or 6.5, the steady state is more difficult to be reached. When pH is close to IEP, the fluctuation can be very important with a slight change of solution environment. The interaction of the membrane surface and the solution species is not predictable. At pH 5.5, 6 or 6.5, the filtration does not reach the steady state even after 2 h. Close to IEP, the rejection is not stable, it is possible that during filtration there is sometimes a slight excess of positive or negative charge on the membrane surface. However, for pH 3, 4, 7 and 8, the steady state was reached after 1 h. Therefore, at least 2 h for a filtration experiment allows considering a credible rejection. Furthermore, the rejection of U is not depending on the molecular weight cut-off of the ceramic membranes (MWCO). Indeed, the same observation was observed for inorganic membranes of MWCO 1 and 5 kDa with minimum permeate flow rate always found at pH 5.5 (Table S2 and Fig. S1.2 in the supporting information). The influence of temperature to the rejection of U is evaluated with experiments at various temperature (10, 22 and 35 °C), the temperature has no influence on the uranium rejection when pH value is very different from IEP (Fig. S1.3 in the supporting information). Fig. S1.4 shows the rejections of U and Na in solution of pH 8.25 from filtration experiments conducted at different applied pressure. The variation of the applied pressure has no significant influence on the U rejection. The electrical interaction between the membrane and U (co-ion) is very strong and is not affected by the pressure. However, rejection of Na (counter-ion) increases largely with the pressure (Fig. S1.4 in the supporting information). This phenomenon can be explained by the following reason. Transport of ions through an ultra/nano filtration membrane is composed by diffusion and convection [43]. At a higher pressure, the permeate flux is higher and the contribution of diffusion becomes less important in comparison to convection, therefore an increase in rejection is observed for monovalent metal ions (counter-ions) [44]. However, researchers believe that by increasing the pressure and permeate flux, more species are transferred to the surface of the membrane [45]. As the permeate flux increases, concentration polarization also intensifies, and this will reduce co-ion rejection. In our case, U species in form of UO₂(CO₃)₃⁴⁻, UO₂(CO₃)₂²⁻ are co-ions of the membrane but are nearly not affected by the pressure. In another study, similar phenomenon is reported, *i.e.*, the rejections of divalent ions (Ca²⁺, Mg²⁺ and SO₄²⁻) are less influenced by the increase of pressure than the monovalent ion (Na⁺ and Cl⁻) [45].

3.1.2. Effect of the ionic strength

The nature of the sodium salts by varying the counter-ions as NaCl, Na₂SO₄ or NaHCO₃ has no influence on the rejection of U in the solution of pH 8.25 (Fig. S1.5, S1.6 and Table S1 in the supporting information). The effect of the ionic strength to the rejection of U is evaluated with the solution of U, NaCl of different concentrations (1.7×10^{-2} to 0.60 mol.L^{-1} ($1\text{--}35 \text{ g.L}^{-1}$, *i.e.* $I = 0.017$ to $0.609 \text{ mol.Kg}^{-1}$) and NaHCO₃ (0 for [NaCl] from 0 to $8.5 \times 10^{-2} \text{ mol.L}^{-1}$ or $1.0 \times 10^{-2} \text{ mol.L}^{-1}$ for [NaCl] > $8.5 \times 10^{-2} \text{ mol.L}^{-1}$). The addition of NaHCO₃ guarantees that there is no uranium precipitation in the solution. The effect of salt concentration was studied using 5 kDa membrane, with an applied pressure of 3 bars, temperature around $22 \pm 2 \text{ }^\circ\text{C}$, a retentate flux of $0.1 \text{ m}^3/\text{h}$. According to Fig. 4, the ionic strength controlled by the NaCl salt concentration has a remarkable influence on the rejection of U. The rejection of U decreases from 100% to 0% with the increase of NaCl concentration from 1.7×10^{-2} to 0.60 mol.L^{-1} ($1\text{--}35 \text{ g.L}^{-1}$, *i.e.* $I = 0.017$ to $0.609 \text{ mol.Kg}^{-1}$). At the same time, the rejection of Na decreases from 10% to 0%. At $8.5 \times 10^{-2} \text{ mol.L}^{-1}$ of NaCl, U rejection is about 50% while Na is only 2.5% rejected. Species distribution of these solutions of U, NaCl and NaHCO₃ have been simulated and are shown in the supporting information.

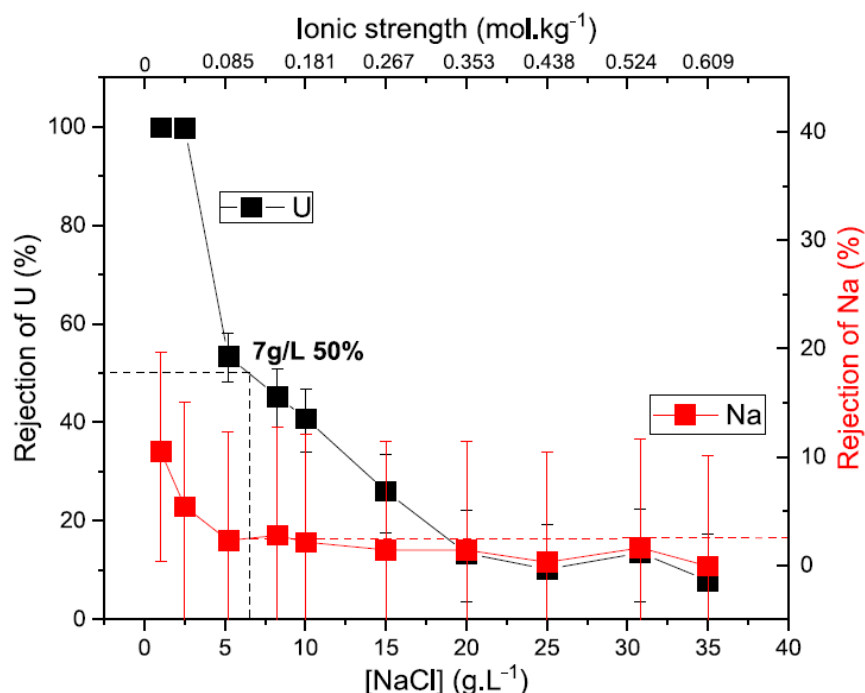

Fig. 4. Rejections of U and Na as a function of NaCl salt concentration.

Despite the different concentration of NaCl, U is always in the form of negatively charged species when the solution pH is 8.25. The only reason for which U is less rejected is the increase of ionic strength. The reason for the decrease of rejections is that the increase of the ionic strength produces

a shielding effect responsible for the decrease of the membrane negative charge along the surface. Accumulation of solute ions at the membrane/solution interface causes screening of the membrane surface charges and compression of the electric double layer. This phenomenon may reduce the ability of the membranes to reject contaminants through electrostatic effects. In this case, with the increase of NaCl concentration, the Na⁺ couples with the negative charge on the membrane surface, shielding the negative charges and reduces the electrical repulsion (Donnan exclusion) between the membrane and negatively charged U species, as a result leading to lower rejection. M. Oo *et al* [46] have studied on the influence of NaCl salt concentration on boron (B(OH)₄⁻) rejection with RO membranes at pH 9 and have measured the zeta potential at each salinity. The rejection of boron decreased with the increase of NaCl salt concentration. The zeta potential increased from \approx 20 to 50 mV when increasing the NaCl salt concentration from 0.5 g.L⁻¹ to 10 g.L⁻¹. At higher NaCl concentrations, zeta potentials generally shifted towards the positive region. They assumed that this phenomenon could be attributed to a stern layer which was densely shielded by positive ions. A major limitation is therefore the salinity of the solution and therefore can be problematic in the context of the recovery of U from seawater. However, with these considerations, it seems interesting to see the applicability on seawaters of weaker ionic strength for concentrating U by ultra/nano filtration. Baltic Sea has a relative low average salinity around 7 g.L⁻¹ [47]. As presented in Fig. 4, in the solutions of U and NaCl at 0.17 mol.L⁻¹ (10 g.L⁻¹), the rejection of U is still 40%, while the rejection of Na is only 2%. The efficient separation of U from Na is still guaranteed in the solution of this salinity.

3.2. Study on competitive metal ions in seawater

The rejections of predominant metal elements in seawater, *i.e.* Ca, Mg, Na, K are compared with the rejection of U obtained from the filtration experiments conducted with the solution of U and NaHCO₃ (U (VI) at 8.40×10^{-5} mol.L⁻¹, NaHCO₃ at 1.0×10^{-2} mol.L⁻¹). Fig. 5 shows the rejections of different metal elements influenced by the solution pH value. The rejection of Mg decreased with the increase of the pH value. The rejection was maximal of 80% when the pH value was close to 3, it decreased successively with the increase of pH value and reached to 0% when pH value is 8. The rejection of Ca decreases from over 60% to 0% when the pH value evolved from 3 to 5.5, then the rejection was found at 20% when pH value is 6, the rejection was of 0% for pH 7 and 8.25. For monovalent alkali metal specie Na, the rejection decreases from 10% to 5% when pH value increases from 3 to 8.25. The rejection of K decreases from 5% at pH 3 to 0% at pH 5.5, then increases to 5% at pH 8.25. At acidic environment, the membrane cannot separate Ca²⁺ from Mg²⁺, since the membrane cannot distinguish the solutes of same valence, but it can separate divalent metal cations from monovalent metal cations. Na⁺ can neither be separated from K⁺. According to the species distribution

of Ca, Mg, Na, K (Fig. S2.1 in the supporting information), all these divalent or monovalent metal species are in the form of cations and none of them precipitates for the whole pH range.

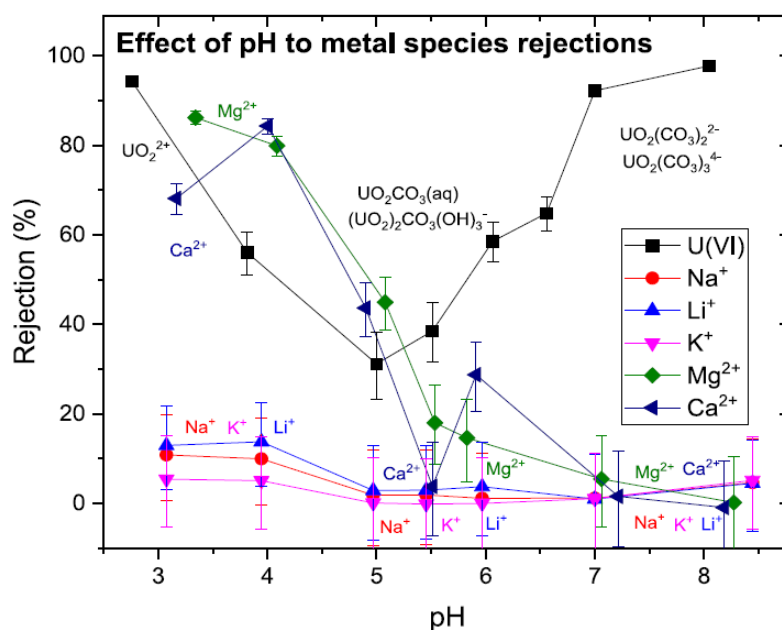

Fig. 3 Influence of pH on the rejections for U, Ca, Mg, Na, K from different solutions, with pH varying from 3 to 8.25: solution 1. $[U] = 8.4 \times 10^{-5} \text{ mol.L}^{-1}$, $[\text{NaHCO}_3] = 1.0 \times 10^{-2} \text{ mol.L}^{-1}$; solution 2. $[\text{Ca}] = 5.00 \times 10^{-4} \text{ mol.L}^{-1}$ (CaCl_2); solution 3. $[\text{Mg}] = 8.23 \times 10^{-4} \text{ mol.L}^{-1}$ (MgCl_2); solution 4. $[\text{Na}] = 8.69 \times 10^{-3} \text{ mg.L}^{-1}$, $[\text{K}] = 5.13 \times 10^{-4} \text{ mol.L}^{-1}$ (NaCl , KCl).

As a result, the electric effect contributes to influence the rejection. At low pH ($\text{pH} < \text{IEP}$), the membrane is positively charged, $X''\text{Cl}_2$ ($X'' = \text{Ca}, \text{Mg}$) rejection is high because the co-ion is divalent (X^{2+}) and the counterion is monovalent (Cl^-). The latter lightly screens the membrane charge. At high pH ($\text{pH} > \text{IEP}$), the membrane is negatively charged. $X\text{Cl}_2$ rejection is low because the co-ion is monovalent (Cl^-) and the counterion is divalent (X^{2+}). The latter screens the membrane charge more strongly. In the case of $X'\text{Cl}$ ($X' = \text{Na}, \text{K}$), X^+ and Cl^- screen both lightly the membrane at weak concentration. As a result, compared to Mg and Ca, the rejections of Na, K are less influenced by the pH value. Finally, it should be noticed that being studied separately, only U as negatively charged uranyl carbonate complex at pH 8.25 is rejected while all the other metal cations can pass through the membrane.

3.3. Study on natural/synthetic water systems

3.3.1. Comparison of rejections in different solutions

Filtration experiments of natural or synthetic waters of different composition and salinity are then conducted. These solutions include seawaters A, B, freshwater F. The applied pressure of the filtration experiment varies from 1 to 3 bars, the temperature is of $22 \text{ }^\circ\text{C}$, the retentate flux is controlled at $0.1 \text{ m}^3/\text{h}$. The rejections are calculated with the concentrations of retentate and permeate after the

filtration reaches to the steady state. The rejection of U obtained by filtration experiments with these solutions are shown in Fig. 6.

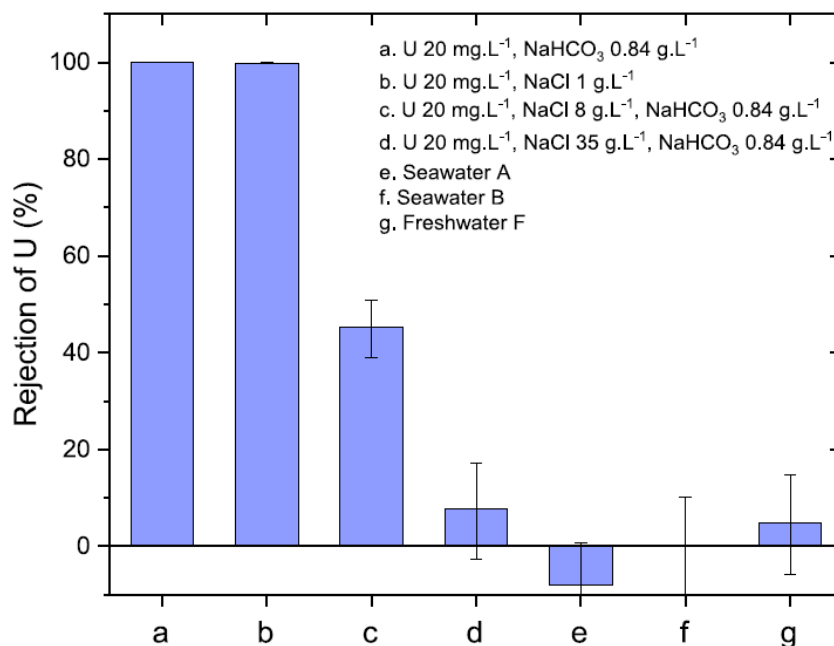

Fig. 6. The rejection of U in the solutions containing only U and Na, and in the solutions containing U, Na, Ca and Mg.

The rejection of U from the other solutions containing only U and Na are also shown in Fig. 6 for a comparison. The rejections of U and the other metals of all these solutions are summarised in Table 1. According to the results in Table 1 and Fig. 6, the conclusion can be drawn that the rejection of U is high in solutions containing only U and sodium salts. However, in natural or synthetic solutions containing U, Ca, Mg, Na, and K, the rejection of U is close to 0%, other metal cations Ca, Mg, Na, K are neither rejected at all. U is not rejected at all in the solutions seawater A, seawater B, is 5% rejected in freshwater F.

The separation of U from the other metals in seawaters or in freshwater cannot be realised. Negative rejection is a normal phenomenon and has been reported in other research on organic membranes [48-51], especially for multi-component electrolyte solutions in the presence of multivalent ions. The membrane properties (*e.g.*, charge and material), the ions in the solution and the operating conditions are some of the parameters that can lead to the membrane surface charge reversal thus to the negative rejections [50]. However, the negative rejections observed here should be the errors, or might be contributed by some complicate electrical mechanisms. The evolution of the rejection of U with time is different depending on the solutions as shown in Table 2. For the solutions containing only U

and Na, the rejection of U remains at the same value despite the time. In the solutions containing Ca or Mg, U is partly rejected at the first 30 min of filtration experiment, but after 1.5 h, U is no more rejected at all. The example of freshwater F (Rhône River doped with U of 2 mg.L⁻¹).

Table 1 Composition of solution and respective rejection of U, Na, Mg, Ca and K.

Solution system	Rejection %				
	U	Na	Mg	Ca	K
U 20 mg.L ⁻¹ NaHCO ₃ 0.84 g.L ⁻¹	100.00 ± 0.01	35.94 ± 6.92			
U 20 mg.L ⁻¹ NaCl 1 g.L ⁻¹	99.86 ± 0.02	10.52 ± 9.66			
U 20 mg.L ⁻¹ NaCl 8 g.L ⁻¹ NaHCO ₃ 0.84 g.L ⁻¹	45.26 ± 5.91	2.76 ± 10.50			
U 20 mg.L ⁻¹ NaCl 35 g.L ⁻¹ NaHCO ₃ 0.84 g.L ⁻¹	7.86 ± 9.95	0.00 ± 10.80			
Mediterranean seawater	-7.88 ± 8.91	1.52 ± 10.63	4.62 ± 10.30	3.60 ± 10.41	0.53 ± 10.74
Synthetic Baltic seawater + U 0.8 mg.L ⁻¹	-0.03 ± 10.80	2.20 ± 10.56	1.89 ± 10.60	1.99 ± 10.59	0.62 ± 10.73
River water + U 2 mg.L ⁻¹	4.95 ± 10.26	1.07 ± 10.68	-1.33 ± 10.94	1.61 ± 10.63	2.36 ± 10.54

Table 2 The uranium rejection of the first and the final samples.

Solution system	Uranium Rejection %	
	t=30 min	t>1.5 h
U 20 mg.L ⁻¹ NaHCO ₃ 0.84 g.L ⁻¹	99.40 ± 0.06	95.90 ± 0.44
U 20 mg.L ⁻¹ NaCl 1 g.L ⁻¹	99.83 ± 0.02	99.74 ± 0.03
U 20 mg.L ⁻¹ NaCl 8 g.L ⁻¹ NaHCO ₃ 0.84 g.L ⁻¹	54.75 ± 4.88	45.26 ± 5.91
U 20 mg.L ⁻¹ NaCl 35 g.L ⁻¹ NaHCO ₃ 0.84 g.L ⁻¹	7.91 ± 9.94	7.86 ± 9.95
Mediterranean seawater	13.77 ± 7.12	-7.88 ± 8.91
Synthetic Baltic seawater + U 0.8 mg.L ⁻¹	32.26 ± 7.31	-0.03 ± 10.80
River water + U 2 mg.L ⁻¹	59.87 ± 4.33	4.95 ± 10.26

At the first 30 min, U is 60% rejected, then the rejection decreases to 5% after 2 h. The 0% rejection of U in the Mediterranean seawater is due to the extreme high solution ionic strength (>35 g.L⁻¹) despite the species distribution. However, the uranium species distributions of the synthetic Baltic seawater shows that at least 50% of uranium species are in the form of Ca₂UO₂(CO₃)₃, CaUO₂(CO₃)₃²⁻, UO₂(CO₃)₃⁴⁻, MgUO₂(CO₃)₃²⁻, and Mg₂UO₂(CO₃)₃ in alkaline environment (pH 7–9). As discussed previously, the electric effect of the filtration is no longer sufficient for the separation of U from sodium salts when the salinity is higher than 10 g/L. In the Baltic seawater, the salinity is around 7–8 g/L, if Mg or Ca salts have no other effect to the electric effect, the rejection of U should be at least 50%. In the freshwater F, with even a lower ionic strength, only 5% of the U is rejected. According to its speciation, U is 85% in the form of Ca₂UO₂(CO₃)₃ and 15% in the form of CaUO₂(CO₃)₃²⁻. The incoherence between the experimental results and the theoretical species distribution highlight that the electric repulsion is more strongly shielded in seawaters and freshwaters. The electric effect is shielded more easily when there is Mg or Ca in the solution.

3.3.2. Influence of Ca or Mg in solution to the rejection of U

To estimate the influence of divalent cations Mg^{2+} and Ca^{2+} on their ability to shield the electric effect, the filtration experiments with the solution of U ($8.4 \times 10^{-5} \text{ mol.L}^{-1}$), Na ($1.0 \times 10^{-2} \text{ mol.L}^{-1}$) with $CaCl_2$ of different concentration ($2.16 \times 10^{-5} - 5.82 \times 10^{-4} \text{ mol.L}^{-1}$) are implemented. Fig. 7 (a) displays the comparison of experimental rejections and theoretical rejections of U and Ca. The experimental rejections are calculated with formula (1) with the concentrations of U and Ca in retentate and permeate samples measured by ICP-OES. Both the rejection of U and Ca decreases from 90% to about 10% when Ca concentration increases from 2.16×10^{-5} to $5.82 \times 10^{-4} \text{ mol.L}^{-1}$ ($CaCl_2$ from 2.4 mg.L^{-1} to 64 mg.L^{-1}). The theoretical rejection of U equals to the proportion of negatively charged U species in the form of $UO_2(CO_3)_3^{4-}$ and $CaUO_2(CO_3)_3^{2-}$ in solution, calculated by $([UO_2(CO_3)_3^{4-}] + [CaUO_2(CO_3)_3^{2-}])/[U]$ at each solution composition (Fig. 7 (b)), the theoretical rejection of Ca equals to the proportion of the negatively charged Ca species, *i.e.*, $CaUO_2(CO_3)_3^{2-}$ in solution, calculated with $[CaUO_2(CO_3)_3^{2-}]/[Ca]$ at each solution composition (Fig. 7 (c)). Fig. 7 (b) and (c) shows respectively the species distribution of U and Ca as a function of $CaCl_2$ concentration. According to Fig. 7 (a), the theoretical rejection of Ca can fit the experimental rejection of Ca. However, the theoretical rejection of U does not fit to its experimental rejection, demonstrating that the species distribution of U cannot predict the rejections when Ca coexists with U in the solution. These experiments demonstrates that the rejection of U decreases sharply with the increase of Ca concentration, and U is only 15% rejected when Ca concentration is of $5.82 \times 10^{-4} \text{ mol.L}^{-1}$, corresponding to 23 mg.L^{-1} . Generally speaking, Ca concentration is over 50 mg.L^{-1} in fresh waters (*e.g.* river waters) and over 500 mg.L^{-1} in salty waters (*e.g.* seawater), the Ca concentration in these natural waters are higher. Accordingly, it is logic that the rejection of U is only 5% in Rhone water and 0% in seawaters of low salinity. The same calculations of species distribution of U and Mg in solutions containing U and $MgCl_2$ are shown in Fig. S2.12 and Fig. S2.13 in the supporting information. Like Ca, the species distribution of U cannot explain the 0% rejection of U in fresh waters. According to the speciation diagrams, the proportion of negatively charged uranium species, *i.e.*, $UO_2(CO_3)_3^{4-}$ and $MgUO_2(CO_3)_3^{2-}$ is always 100% despite different concentration of Mg, predicting that U is supposed to be 100% rejected in any solutions of low ionic strength only containing U, Na and Mg. In a filtration experiment conducted with the solution containing 20 mg.L^{-1} of U, 4.2 g.L^{-1} of $MgCl_2$ and 0.84 g.L^{-1} of $NaHCO_3$, the rejection of U was 0%. In another experiment conducted with the solution containing 20 mg.L^{-1} of U, 1.0 g.L^{-1} of $MgCl_2$, 5.0 g.L^{-1} of NaCl and 0.84 g.L^{-1} of $NaHCO_3$, the rejection of U was 4.6%. Fig. S2.14 and Fig. S2.15 show the species distribution of U, Ca and Mg as function of the concentration of divalent salt XCl_2 ($X = Ca, Mg$) in solution. With the increase of concentration $[X]$, the total proportion of $UO_2(CO_3)_3^{4-}$, $CaUO_2(CO_3)_3^{2-}$ and $MgUO_2(CO_3)_3^{2-}$ decreases sharply, the proportion of $Ca_2UO_2(CO_3)_3$ is over 80% when $[X]$ is higher than

3 mmol.L⁻¹. The rejection of U in solution of low ionic strength containing U, Mg, Ca and Na should be at least higher than 15%, which is not observed with fresh water. To conclude, U can be separated and concentrated by filtration process by electrical repulsion in solutions at alkaline environment of salinity weaker than 10 g.L⁻¹ with no presence of Mg or Ca.

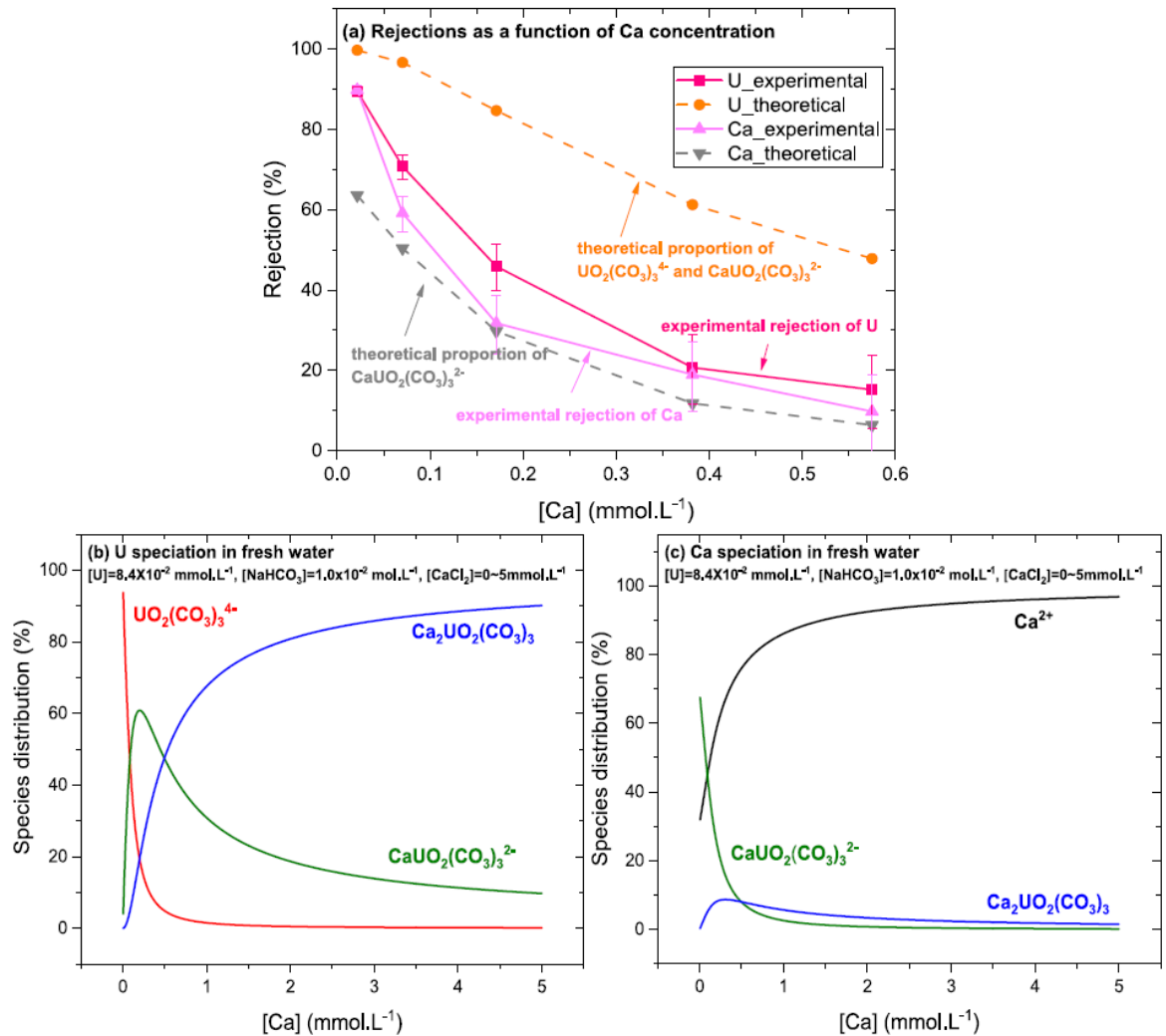

Fig. 4 (a) Theoretical rejection and experimental rejection of U and Ca of filtration with solution 13. (b) Species distribution of U in solution 13. (c) Species distribution of Ca in solution 13. Solution composition: U 8.4×10^{-5} mol.L⁻¹, NaHCO₃ 1.0×10^{-2} mol.L⁻¹, CaCl₂ $2.16 \times 10^{-5} \sim 5.82 \times 10^{-4}$ mol.L⁻¹. Drawn by PHREEQC, based on the formation constants of Ca-UO₂-CO₃, Mg-UO₂-CO₃, NEA TDB database updated in December 2020. Minor U species are not shown.

3.3.3. Interpretations and discussions of the observed phenomenon

Three possible reasons which caused the 0% rejection of U when Ca or Mg is in the solution are proposed as following. The first possible reason is that, despite the existence of negatively charged complexes CaUO₂(CO₃)₃²⁻ and MgUO₂(CO₃)₃²⁻, they are bonded to cations present in solutions. As a

result, together with the cations around these complexes, the global charge is not negative to be rejected by the membrane (Fig. 8 (a)). Satoru Tsushima *et al* found that the uranyl tricarbonate complex, which has high negative charge (-4), is expected to have strong interactions with the counter ions. It suggests that counter ion(s) play a very important roles in the electronic and geometric structures of the uranyl tricarbonate complex [52].

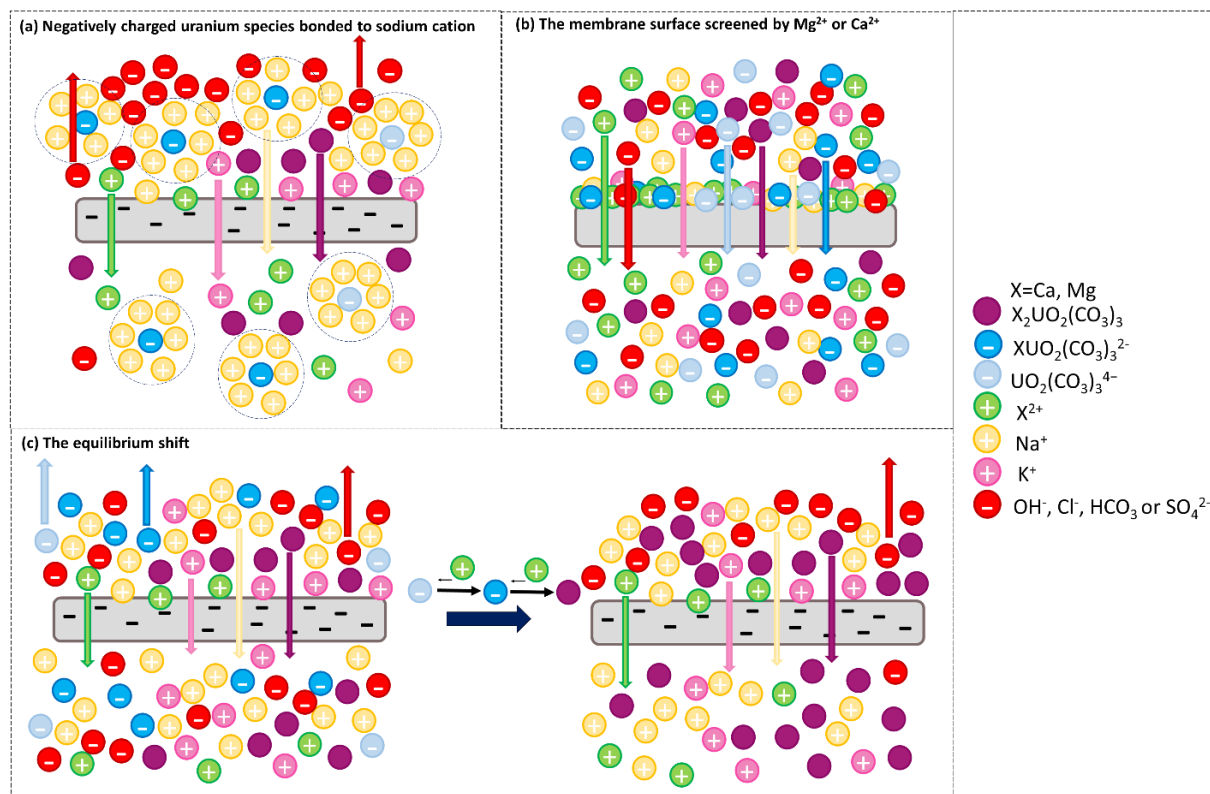
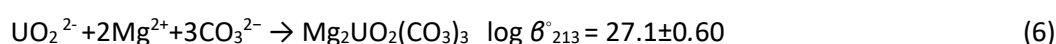
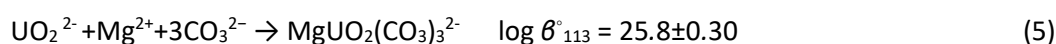
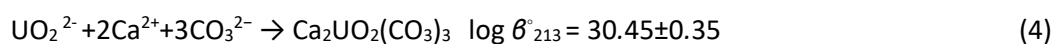
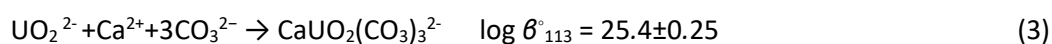

Fig. 5 Illustration of three hypothesis for the 0% rejection of U. (a) Negatively charged uranium species bonded to sodium cation. (b) The membrane surface screened by Mg^{2+} or Ca^{2+} . (c) The equilibrium shift.

Shelly D. Kelly *et al* demonstrated with X-ray absorption spectroscopy measurement that the number of calcium and/or sodium atoms coordinated to a uranyl carbonate complex will determine the net charge of the complex. On the average, approximately 2 calcium atoms are bound to the uranyl carbonate species at the highest concentrations and 2–4 sodium atoms are bound to the uranyl carbonate species when calcium is absent. The effect on the bond strength with more single charged sodium atoms ($4Na^+$ atoms), as compared to fewer doubly charged calcium atoms ($2Ca^{2+}$ atoms) bound to the $UO_2(CO_3)_3^{4-}$ moiety, would suggest that the $UO_2(CO_3)_3^{4-}Na_4^{4+}$ bond is weaker than the $UO_2(CO_3)_3^{4-}Ca_2^{4+}$ bond [53]. Weihong Wu *et al* suggested that the structure of the $Ca_2UO_2(CO_3)_3$ complex is very stable in the seawater model. A Na^+ ion was found to be closely associated with the $Ca_2UO_2(CO_3)_3$ complex at a U - Na distance of 5.25 Å, while the Cl ion is at least 11 Å away from U. The

Na^+ ion interacts indirectly with one axial oxygen atom of the UO_2 group bridged by a water molecule. In addition, the Na^+ ion interacts more closely with one Ca^{2+} ion than the other. The present simulations revealed the key role of common ions such as Na^+ in impacting the solvation, structure, and apparent charge of the $\text{Ca}_2\text{UO}_2(\text{CO}_3)_3$ complex in seawater [54]. Another possible reason is that the Ca^{2+} or Mg^{2+} have been adsorbed on the membrane surface. As a result, the membrane surface is less negatively charged. At the same time, Donnan potential is known to be seriously influenced by the valance of ions present in the feed. Specifically, the Donnan potential is weakest in solutions with a higher concentration of divalent cations [55]. The influence of the electrolyte types and concentration (1 mM KCl, 0.1 mM CaCl_2 , 1 mM CaCl_2 and 1 mM MgSO_4) to the membrane zeta potential along the surface in the pH range 4.0–8.3, with the electrolytes have been implanted by M. Teixeira *et al* [31]. In the presence of Ca^{2+} , the tested membrane was more positively charged over the entire pH range and the IEP shifts from 4.2 to 5–6. When both divalent cations (Mg^{2+}) and anions (SO_4^{2-}) were present in solution, the effect of the divalent anion was opposite to the effect of the divalent cation, Mg^{2+} adsorbs less than Ca^{2+} , therefore the zeta potential curve was intermediate between the curves obtained for KCl and CaCl_2 . S. Deshmukh *et al* [56] has investigated the influence of feed water on the zeta potential of the membrane surface. They also observed the zeta potential has increased with river water. They assumed that the divalent cations (Ca^{2+} , Mg^{2+}) have been absorbed on the membrane surface. M. Giagnorio *et al* [57] have worked on the rejection of CrO_4^{2-} with polyamide membranes which are negatively charged under natural pH conditions. The effect of the ionic composition and of the salt concentration has been evaluated. They observed that Cr(VI) rejection decreased with the increase of salt concentration, but NaCl had less effect on Cr(VI) rejection than CaCl_2 at the same ionic strength and the same permeate flux. As a result, this phenomenon was not attributed to concentration polarization. They assumed that the presence of divalent cations in solution might induce the formation of ion pairs with the negative functional groups at membrane surface, thus lowering its overall charge and allowing the passage of Cr(VI) [57]. Their measurements on the zeta potential corroborated this discussion. At neutral pH, the potential was much lower in magnitude in CaCl_2 solutions compared with NaCl solutions with similar ionic strength. This result strengthens the hypothesis of specific chemical interactions of calcium with membrane moieties, resulting neutralization of charges and causing the easier passage of Cr(VI) through membranes governed by electrostatic effects as separation mechanism. The larger effect of calcium compared to sodium at similar ionic strengths is attributed to chemical pairing of this divalent cation with the functionalities of the membrane, which lowers the overall surface potential. Illustrated in Fig. 8 (b), in our case, the inorganic membranes used in our research have amphoteric behaviour of mineral oxides, hydroxyl groups on the material surface can also react with cations in the solution. Ca^{2+} , Mg^{2+} could react with the membrane surface then shield the negative charges at the membrane interface significantly

decreased the rejection of co-ions (U species) at pH 8.25. To confirm this hypothesis, zeta potential measurements should be conducted. The final and the most probable reason is the 0% rejection of U with the presence of Ca²⁺ and Mg²⁺ could be the continuous formation of Ca₂UO₂(CO₃)₃ and Mg₂UO₂(CO₃)₃ on the membrane surface for establishing the reaction equilibrium during the filtration (Fig. 8 (c)). This hypothesis is based on the hypothesis that the membrane surface charge is not screened by Ca²⁺ or Mg²⁺: The kinetics of mixed U-Ca-CO₃ complex formation due to the very high association constant between UO₂²⁺, Ca²⁺ and CO₃²⁻ is clearly higher than the transport rate of the permeate at the outlet of the membrane towards the reservoir of the feed caused by the big difference between the flow rates of permeate and retentate, and by the long distance for permeate to return to the feed tank. The permeate flux is around 0.1–0.3 L/h, negligible to the retentate flux of 100 L/h. The membrane carter is far to the feed tank, there is a large difference between the time for the permeate and the retentate to return into the feed. Meanwhile, the space between the membrane and the membrane carter can be considered as an intermediate recipient of a capacity to contain 50–100 mL permeate solution. As a result, when the species composition of permeate is totally different to the retentate, the chemical equilibrium shift at this intermediate recipient could happen. Fig. 8 (c) shows a schematic explanation of this hypothesis. At the beginning of the filtration experiment, more than 50% of U under Ca₂UO₂(CO₃)₃ form passes through the membrane, while CaUO₂(CO₃)₃²⁻ is rejected. The “lack” of Ca₂UO₂(CO₃)₃ on the membrane surface becomes a stress of the equilibrium. According to Le Chatelier principle, and based on the continuous equilibrium displacement, the system continues to proceed toward a new equilibrium, leading to encourage the reaction to produce more Ca₂UO₂(CO₃)₃ from CaUO₂(CO₃)₃²⁻. As a result, the chemical equilibrium is never reached until all CaUO₂(CO₃)₃²⁻ transfers to Ca₂UO₂(CO₃)₃. Once Ca₂UO₂(CO₃)₃ is produced, the reverse reaction to form CaUO₂(CO₃)₃²⁻ is unfavourable to proceed since the chemical equilibrium constant for producing Ca₂UO₂(CO₃)₃ is higher than that of CaUO₂(CO₃)₃²⁻ [58]. The same trend is applicable with Mg-UO₂-CO₃ species, as represented in equations (3)-(6) [3,4,]. Therefore, all U passes through the membrane since there is no more enough negatively charged U species to induce the electrical repulsion interaction.



4. Conclusions

The objective of this study was to examine the possibility to separate and/or concentrate uranium from other salts in water systems by UF/NF filtration process with inorganic membranes, and evaluating the rejection mechanism, the interaction of membrane with solution species. Influence of various physio-chemical parameters to solute rejections during filtration were studied, for example, MWCO, pH value of solutions, temperature, applied pressure, ionic strength/salinity, composition of the solutions, etc. Several conclusions were drawn based on the above experiments. Electrical repulsion and attraction is the key mechanism for the solute rejection, therefore pH value is an important determining factor of solute rejection since the species distribution could be quite different when pH changes. The separation of U to Na can be performed at pH 3 and 8.25 in solutions of U and NaHCO₃. MWCO, temperature does not influence the rejection of U, higher applied-to-membrane pressure does not permeate higher U rejection at pH 8.25. Nevertheless, fluctuations can be enormous when pH value is close to IEP. With filtration experiments of solutions with U, NaHCO₃ and NaCl (1–35 g.L⁻¹), a huge impact of solution ionic strength to rejections was observed. U rejection decreases from 100% to 0% when increasing the NaCl concentration from 1 g.L⁻¹ to 35 g.L⁻¹. The separation of U from Na can still be guaranteed when the salinity is lower than 10 g.L⁻¹. The filtration experiments of natural and synthetic solutions including seawaters, Rhone River show that none of the solutes (U, Na, Mg, Ca, K) can be rejected by Donnan electrical exclusion. Finally, filtration experiments on solutions of U with CaCl₂ at different concentration demonstrated that U rejection decreases with the increase of Ca/Mg concentration. Three hypotheses have been proposed to explain the invalidity of electric effect to reject U in solutions with Ca or Mg. Further studies on applying complexation with ultra/nano filtration to concentrate U from seawaters are under investigation.

Acknowledgment

The authors are grateful to the China Scholarship Council (CSC) for PhD funding. The authors acknowledge Béatrice Baus-Lagarde, for her help regarding the ICP/OES and ICP/MS experiments.

References

- [1] P. Loganathan, G. Naidu, S. Vigneswaran, Mining valuable minerals from seawater: A critical review, *Environ. Sci. (Camb)*. 3 (2017), <https://doi.org/10.1039/c6ew00268d>.
- [2] U. Bardi, Extracting minerals from seawater: An energy analysis, *Sustainability*. 2 (2010), <https://doi.org/10.3390/su2040980>.
- [3] J.Y. Lee, M. Vespa, X. Gaona, K. Dardenne, J. Rothe, T. Rabung, M. Altmaier, J. Il Yun, Formation, stability and structural characterization of ternary $\text{MgUO}_2(\text{CO}_3)_3^{2-}$ and $\text{Mg}_2\text{UO}_2(\text{CO}_3)_3(\text{aq})$ complexes, *Radiochim. Acta*. 105 (2017) 171–185, <https://doi.org/10.1515/ract-2016-2643>.
- [4] J.Y. Lee, J. Il Yun, Formation of ternary $\text{CaUO}_2(\text{CO}_3)_3^{2-}$ and $\text{Ca}_2\text{UO}_2(\text{CO}_3)_3(\text{aq})$ complexes under neutral to weakly alkaline conditions, *J. Chem. Soc. Dalton Trans.* 42 (2013) 9862–9869, <https://doi.org/10.1039/c3dt50863c>.
- [5] J. Kim, C. Tsouris, R.T. Mayes, Y. Oyola, T. Saito, C.J. Janke, S. Dai, E. Schneider, D. Sachde, Recovery of Uranium from Seawater: A Review of Current Status and Future Research Needs, *Separ. Sci. Technol. (Philadelphia)*. 48 (2013) 367–387, <https://doi.org/10.1080/01496395.2012.712599>.
- [6] M.S. Diallo, M.R. Kotte, M. Cho, Mining Critical Metals and Elements from Seawater: Opportunities and Challenges, *Environ. Sci. Technol.* 49 (2015) 9390–9399, <https://doi.org/10.1021/acs.est.5b00463>.
- [7] C.W. Abney, R.T. Mayes, T. Saito, S. Dai, Materials for the Recovery of Uranium from Seawater, *Chem. Rev.* 117 (2017) 13935–14013, <https://doi.org/10.1021/acs.chemrev.7b00355>.
- [8] J. Zeng, H. Zhang, Y. Sui, N. Hu, D. Ding, F. Wang, J. Xue, Y. Wang, New Amidoxime-Based Material TMP-g-AO for Uranium Adsorption under Seawater Conditions, *Ind. Eng. Chem. Res.* 56 (2017) 5021–5032, <https://doi.org/10.1021/acs.iecr.6b05006>.
- [9] X. Xu, X.J. Ding, J.X. Ao, R. Li, Z. Xing, X.Y. Liu, X.J. Guo, G.Z. Wu, H.J. Ma, X. Y. Zhao, Preparation of amidoxime-based PE/PP fibers for extraction of uranium from aqueous solution, *Nuclear Sci. Tech.* 30 (2019) 20, <https://doi.org/10.1007/s41365-019-0543-0>.
- [10] N. Tang, J. Liang, C. Niu, H. Wang, Y. Luo, W. Xing, S. Ye, C. Liang, H. Guo, J. Guo, Y. Zhang, G. Zeng, Amidoxime-based materials for uranium recovery and removal, *J. Mater. Chem. A Mater.* 8 (2020) 7588–7625, <https://doi.org/10.1039/c9ta14082d>.
- [11] Y. Yuan, T. Liu, J. Xiao, Q. Yu, L. Feng, B. Niu, S. Feng, J. Zhang, N. Wang, DNA nano-pocket for ultra-selective uranyl extraction from seawater, *Nat. Commun.* 11 (2020) 5708, <https://doi.org/10.1038/s41467-020-19419-z>.

- [12] Y. Yuan, Q. Yu, J. Wen, C. Li, Z. Guo, X. Wang, N. Wang, Ultrafast and Highly Selective Uranium Extraction from Seawater by Hydrogel-like Spidroin-based Protein Fiber, *Angewandte Chemie International Edition*. 58 (2019) 11785–11790, <https://doi.org/10.1002/anie.201906191>.
- [13] Y. Yuan, Q. Yu, M. Cao, L. Feng, S. Feng, T. Liu, T. Feng, B. Yan, Z. Guo, N. Wang, Selective extraction of uranium from seawater with biofouling-resistant polymeric peptide, *Nat. Sustain.* 4 (2021) 708–714, <https://doi.org/10.1038/s41893-021-00709-3>.
- [14] V. Vatanpour, M. Esmaeili, M.H.D.A. Farahani, Fouling reduction and retention increment of polyethersulfone nanofiltration membranes embedded by amine-functionalized multi-walled carbon nanotubes, *J. Memb. Sci.* 466 (2014) 70–81, <https://doi.org/10.1016/j.memsci.2014.04.031>.
- [15] J. Song, T. Huang, H. Qiu, X. Niu, X.M. Li, Y. Xie, T. He, A critical review on membrane extraction with improved stability: Potential application for recycling metals from city mine, *Desalination*. 440 (2018) 18–38, <https://doi.org/10.1016/j.desal.2018.01.007>.
- [16] X. Zhang, W. Zhao, Y. Zhang, V. Jegatheesan, A review of resource recovery from seawater desalination brine, *Rev. Environ. Sci. Biotechnol.* 20 (2021) 333–361, <https://doi.org/10.1007/s11157-021-09570-4>.
- [17] A. Taghvaie Nakhjiri, H. Sanaeepur, A. Ebadi Amooghin, M.M.A. Shirazi, Recovery of precious metals from industrial wastewater towards resource recovery and environmental sustainability: A critical review, *Desalination*. 527 (2022), 115510, <https://doi.org/10.1016/j.desal.2021.115510>.
- [18] A. Favre-Réguillon, A. Sorin, S. Pellet-Rostaing, G. Bernier, M. Lemaire, Nanofiltration assisted by complexation: A promising process for the separation of trivalent long-lived minor actinides from lanthanides, *Comptes Rendus Chimie*. 10 (2007) 994–1000, <https://doi.org/10.1016/j.crci.2007.01.012>.
- [19] F. Chitry, S. Pellet-Rostaing, C. Gozzi, M. Lemaire, Separation of lanthanides(III) by nanofiltration-complexation in aqueous medium, *Sep. Sci. Technol.* 36 (2001) 605–618, <https://doi.org/10.1081/SS-100102949>.
- [20] F. Chitry, S. Pellet-Rostaing, A. Guy, J. Foos, M. Lemaire, Separation of americium (III) from lanthanides(III) by nanofiltration-complexation in aqueous medium, *J. Radioanal. Nucl. Chem.* 251 (2002) 155–157, <https://doi.org/10.1023/A:1015075101632>.
- [21] A. Sorin, A. Favre-Réguillon, S. Pellet-Rostaing, M. Sbaï, A. Szymczyk, P. Fievet, M. Lemaire, Rejection of Gd(III) by nanofiltration assisted by complexation on charged organic membrane:

Influences of pH, pressure, flux, ionic strength and temperature, *J. Memb. Sci.* 267 (2005) 41–49, <https://doi.org/10.1016/j.memsci.2005.05.022>.

[22] J. Borrini, A. Favre-Réguillon, M. Lemaire, S. Gracia, G. Arrachart, G. Bernier, X. Hérés, C. Hill, S. Pellet-Rostaing, Water Soluble PDCA Derivatives for Selective Ln(III)/An(III) and Am(III)/Cm(III) Separation, Solvent Extraction and Ion, Exchange. 33 (2015) 224–235, <https://doi.org/10.1080/07366299.2014.974449>.

[23] J. Borrini, G. Bernier, S. Pellet-Rostaing, A. Favre-Réguillon, M. Lemaire, Separation of lanthanides(III) by inorganic nanofiltration membranes using a water soluble complexing agent, *J. Memb. Sci.* 348 (2010) 41–46, <https://doi.org/10.1016/j.memsci.2009.10.034>.

[24] A. Favre-Réguillon, G. Lebuzit, D. Murat, J. Foos, C. Mansour, M. Draye, Selective removal of dissolved uranium in drinking water by nanofiltration, *Water Res.* 42 (2008) 1160–1166, <https://doi.org/10.1016/j.watres.2007.08.034>.

[25] A. Favre-Reguillon, G. Lebuzit, J. Foos, A. Guy, M. Draye, M. Lemaire, Selective Concentration of Uranium from Seawater by Nanofiltration, *Ind. Eng. Chem. Res.* 42 (2003) 5900–5904, <https://doi.org/10.1021/ie030157a>.

[26] J. Ramkumar, K.S. Shrimal, B. Maiti, T.S. Krishnamoorthy, Selective permeation of Cu²⁺ and UO₂²⁺ through a Nafion ionomer membrane, *J. Memb. Sci.* 116 (1996) 31–37, [https://doi.org/10.1016/0376-7388\(96\)00007-5](https://doi.org/10.1016/0376-7388(96)00007-5).

[27] T.M. McCleskey, D.S. Ehler, J.S. Young, D.R. Pesiri, G.D. Jarvinen, N.N. Sauer, Asymmetric membranes with modified gold films as selective gates for metal ion separations, *J. Memb. Sci.* 210 (2002) 273–278, [https://doi.org/10.1016/S0376-7388\(02\)00387-3](https://doi.org/10.1016/S0376-7388(02)00387-3).

[28] L.A. Richards, B.S. Richards, A.I. Schäfer, Renewable energy powered membrane technology: Salt and inorganic contaminant removal by nanofiltration/reverse osmosis, *J. Memb. Sci.* 369 (2011) 188–195, <https://doi.org/10.1016/j.memsci.2010.11.069>.

[29] Y.A. Boussouga, B.S. Richards, A.I. Schäfer, Renewable energy powered membrane technology: System resilience under solar irradiance fluctuations during the treatment of fluoride-rich natural waters by different nanofiltration/reverse osmosis membranes, *J. Memb. Sci.* 617 (2021), 118452, <https://doi.org/10.1016/j.memsci.2020.118452>.

[30] C. Oumar Anne, D. Trébouet, P. Jaouen, F. Quéméneur, Nanofiltration of seawater: Fractionation of mono-and multi-valent cations, *Desalination.* 140 (2001) 67–77, [https://doi.org/10.1016/S0011-9164\(01\)00355-1](https://doi.org/10.1016/S0011-9164(01)00355-1).

- [31] M.R. Teixeira, M.J. Rosa, M. Nyström, The role of membrane charge on nanofiltration performance, *J. Memb. Sci.* 265 (2005) 160–166, <https://doi.org/10.1016/j.memsci.2005.04.046>.
- [32] J. Schaep, B. Van Der Bruggen, C. Vandecasteele, D. Wilms, Influence of ion size and charge in nanofiltration, *Sep. Purif. Technol.* 14 (1998) 155–162, [https://doi.org/10.1016/S1383-5866\(98\)00070-7](https://doi.org/10.1016/S1383-5866(98)00070-7).
- [33] A.E. Childress, M. Elimelech, Effect of solution chemistry on the surface charge of polymeric reverse osmosis and nanofiltration membranes, *J. Memb. Sci.* 119 (1996) 253–268, [https://doi.org/10.1016/0376-7388\(96\)00127-5](https://doi.org/10.1016/0376-7388(96)00127-5).
- [34] B. Das, B. Chakrabarty, P. Barkakati, Preparation and characterization of novel ceramic membranes for micro-filtration applications, *Ceram. Int.* 42 (2016) 14326–14333, <https://doi.org/10.1016/j.ceramint.2016.06.125>.
- [35] M. Kniebusch, H.E.M. Meier, H. Radtke, Changing Salinity Gradients in the Baltic Sea As a Consequence of Altered Freshwater Budgets, *Geophys. Res. Lett.* 46 (2019) 9739–9747, <https://doi.org/10.1029/2019GL083902>.
- [36] M.D. Afonso, M.N. De Pinho, Transport of MgSO₄, MgCl₂, and Na₂SO₄ across an amphoteric nanofiltration membrane, *J. Memb. Sci.* 179 (2000) 137–154, [https://doi.org/10.1016/S0376-7388\(00\)00495-6](https://doi.org/10.1016/S0376-7388(00)00495-6).
- [37] V. Jacquet Violleau, D'éminéralisation par électrodialyse en présence d'un complexant: Application au Lactoserum, Institut National Polytechnique de Toulouse, 1999. <https://oatao.univ-toulouse.fr/7349/>.
- [38] S. Condom, A. Larbot, S.A. Younssi, M. Persin, Use of ultra- and nanofiltration ceramic membranes for desalination, *Desalination.* 168 (2004) 207–213, <https://doi.org/10.1016/j.desal.2004.06.189>.
- [39] T. Van Gestel, C. Vandecasteele, A. Buekenhoudt, C. Dotremont, J. Luyten, R. Leysen, B. Van Der Bruggen, G. Maes, Salt retention in nanofiltration with multilayer ceramic TiO₂ membranes, *J. Memb. Sci.* 209 (2002) 379–389, [https://doi.org/10.1016/S0376-7388\(02\)00311-3](https://doi.org/10.1016/S0376-7388(02)00311-3).
- [40] J.M.M. Peeters, J.P. Boom, M.H.V. Mulder, H. Strathmann, Retention measurements of nanofiltration membranes with electrolyte solutions, *J. Memb. Sci.* 145 (1998) 199–209, [https://doi.org/10.1016/S0376-7388\(98\)00079-9](https://doi.org/10.1016/S0376-7388(98)00079-9).
- [41] T. Tsuru, H. Takezoe, M. Asaeda, Ion Separation by Porous Silica-Zirconia Nanofiltration Membranes, *AIChE J.* 44 (1998) 765–768, <https://doi.org/10.1002/aic.690440324>.

- [42] S.L. Ong, W. Zhou, L. Song, W.J. Ng, Evaluation of feed concentration effects on salt/ion transport through RO/NF membranes with the Nernst-Planck-Donnan model, *Environ. Eng. Sci.* 19 (2002) 429–439, <https://doi.org/10.1089/109287502320963418>.
- [43] N. Hilal, H. Al-Zoubi, N.A. Darwish, A.W. Mohammad, M. Abu Arabi, A comprehensive review of nanofiltration membranes: Treatment, pretreatment, modelling, and atomic force microscopy, *Desalination*. 170 (2004), 281–308. [10.1016/j.desal.2004.01.007](https://doi.org/10.1016/j.desal.2004.01.007).
- [44] H. Al-Zoubi, W. Omar, Rejection of salt mixtures from high saline by nanofiltration membranes, *Korean J. Chem. Eng.* 26 (2009) 799–805, <https://doi.org/10.1007/s11814-009-0133-7>.
- [45] B.A. Abdelkader, M.A. Antar, Z. Khan, Nanofiltration as a Pretreatment Step in Seawater Desalination: A Review, *Arab. J. Sci. Eng.* 43 (2018) 4413–4432, <https://doi.org/10.1007/s13369-018-3096-3>.
- [46] M.H. Oo, S.L. Ong, Implication of zeta potential at different salinities on boron removal by RO membranes, *J. Memb. Sci.* 352 (2010) 1–6, <https://doi.org/10.1016/j.memsci.2010.01.030>.
- [47] J.D. Müller, Ocean acidification in the Baltic Sea: involved processes, metrology of pH in brackish waters, and calcification under fluctuating conditions, 2018. DOI: [10.18453/rosdok_id00002303](https://doi.org/10.18453/rosdok_id00002303).
- [48] I. Jitsuhara, S. Kimura, Rejection of inorganic salts by charged ultrafiltration membranes made of sulfonated polysulfone, *J. Chem. Eng. Japan*. 16 (1983) 394–399, <https://doi.org/10.1252/jcej.16.394>.
- [49] J. Gilron, N. Gara, O. Kedem, Experimental analysis of negative salt rejection in nanofiltration membranes, *J. Memb. Sci.* 185 (2001) 223–236, [https://doi.org/10.1016/S0376-7388\(00\)00639-6](https://doi.org/10.1016/S0376-7388(00)00639-6).
- [50] A.E. Yaroshchuk, Negative rejection of ions in pressure-driven membrane processes, *Adv. Colloid Interf. Sci.* 139 (2008) 150–173, <https://doi.org/10.1016/j.cis.2008.01.004>.
- [51] J. Garcia-Aleman, J.M. Dickson, Permeation of mixed-salt solutions with commercial and pore-filled nanofiltration membranes: membrane charge inversion phenomena, *J. Memb. Sci.* 239 (2004) 163–172, <https://doi.org/10.1016/j.memsci.2004.02.036>.
- [52] S. Tsushima, Y. Uchida, T. Reich, A theoretical study on the structures of $\text{UO}_2(\text{CO}_3)_4^{4-}$, $\text{Ca}_2\text{UO}_2(\text{CO}_3)_3$, and $\text{Ba}_2\text{UO}_2(\text{CO}_3)_3$, *Chem. Phys. Lett.* 357 (2002) 73–77, [https://doi.org/10.1016/S0009-2614\(02\)00443-8](https://doi.org/10.1016/S0009-2614(02)00443-8).
- [53] S.D. Kelly, K.M. Kemner, S.C. Brooks, X-ray absorption spectroscopy identifies calcium-uranyl-carbonate complexes at environmental concentrations, *Geochim. Cosmochim. Acta.* 71 (2007) 821–834, <https://doi.org/10.1016/j.gca.2006.10.013>.

- [54] W. Wu, C. Priest, J. Zhou, C. Peng, H. Liu, D.E. Jiang, Solvation of the $\text{Ca}_2\text{UO}_2(\text{CO}_3)_3$ Complex in Seawater from Classical Molecular Dynamics, *J. Phys. Chem. B.* 120 (2016) 7227–7233, <https://doi.org/10.1021/acs.jpcc.6b05452>.
- [55] M. Higa, A. Tanioka, A. Kira, A novel measurement method of Donnan potential at an interface between a charged membrane and mixed salt solution, *J. Memb. Sci.* 140 (1998) 213–220, [https://doi.org/10.1016/S0376-7388\(97\)00284-6](https://doi.org/10.1016/S0376-7388(97)00284-6).
- [56] S.S. Deshmukh, A.E. Childress, Zeta potential of commercial RO membranes: Influence of source water type and chemistry, *Desalination.* 140 (2001) 87–95, [https://doi.org/10.1016/S0011-9164\(01\)00357-5](https://doi.org/10.1016/S0011-9164(01)00357-5).
- [57] M. Giagnorio, B. Ruffino, D. Grinic, S. Steffenino, L. Meucci, M.C. Zanetti, A. Tiraferri, Achieving low concentrations of chromium in drinking water by nanofiltration: membrane performance and selection, *Environm. Sci. Pollut. Res.* 25 (2018) 25294–25305, <https://doi.org/10.1007/s11356-018-2627-5>.
- [58] G. Bernhard, G. Geipel, T. Reich, V. Brendler, S. Amayri, H. Nitsche, H. Nitsche, Uranyl(VI) carbonate complex formation: Validation of the $\text{Ca}_2\text{UO}_2(\text{CO}_3)_3(\text{aq.})$ species, *Radiochim Acta.* 89 (2001) 511. [10.1524/ract.2001.89.8.511](https://doi.org/10.1524/ract.2001.89.8.511)