



HAL
open science

Fused Deposition Modeling (FDM), the new asset for the production of tailored medicines

Sylvain Cailleaux, Noelia Sanchez-Ballester, Yanis Gueche, Bernard Bataille,
Ian Soulairol

► **To cite this version:**

Sylvain Cailleaux, Noelia Sanchez-Ballester, Yanis Gueche, Bernard Bataille, Ian Soulairol. Fused Deposition Modeling (FDM), the new asset for the production of tailored medicines. *Journal of Controlled Release*, 2021, 330, pp.821-841. 10.1016/j.jconrel.2020.10.056 . hal-03617438

HAL Id: hal-03617438

<https://hal.umontpellier.fr/hal-03617438v1>

Submitted on 10 Mar 2023

HAL is a multi-disciplinary open access archive for the deposit and dissemination of scientific research documents, whether they are published or not. The documents may come from teaching and research institutions in France or abroad, or from public or private research centers.

L'archive ouverte pluridisciplinaire **HAL**, est destinée au dépôt et à la diffusion de documents scientifiques de niveau recherche, publiés ou non, émanant des établissements d'enseignement et de recherche français ou étrangers, des laboratoires publics ou privés.



Distributed under a Creative Commons Attribution - NonCommercial 4.0 International License

Fused Deposition Modeling (FDM), the new asset for the production of tailored medicines

Sylvain Cailleaux^{1,2}, Noelia M Sanchez-Ballester¹, Yanis A Gueche¹, Bernard Bataille¹, and Ian Soulairol^{1,2}

¹ ICGM, Univ Montpellier, CNRS, ENSCM, Montpellier, France

² Department of Pharmacy, Nîmes University Hospital, Nimes, France

Corresponding author: ian.soulairol@umontpellier.fr

ABSTRACT: Over the last few years, conventional medicine has been increasingly moving towards precision medicine. Today, the production of oral pharmaceutical forms tailored to patients is not achievable by traditional industrial means. A promising solution to customize oral drug delivery has been found in the utilization of 3D Printing and in particular Fused Deposition Modeling (FDM). Thus, the aim of this systematic literature review is to provide a synthesis on the production of pharmaceutical solid oral forms using FDM technology. In total, 72 relevant articles have been identified *via* two well-known scientific databases (PubMed and ScienceDirect). Overall, three different FDM methods have been reported: "Impregnation-FDM", "Hot Melt Extrusion coupled with FDM" and "Print-fill", which yielded to the formulation of thermoplastic polymers used as main component, five families of other excipients playing different functional roles and 47 active ingredients. Solutions are underway to overcome the high printing temperatures, which was the initial brake on to use thermosensitive ingredients with this technology. Also, the moisture sensitivity shown by a large number of prints in preliminary storage studies is highlighted. FDM seems to be especially fitted for the treatment of rare diseases, and particular populations requiring tailored doses or release kinetics. For future use of FDM in clinical trials, an implication of health regulatory agencies would be necessary. Hence, further efforts would likely be oriented to the use of a quality approach such as "Quality by Design" which could facilitate its approval by the authorities, and also be an aid to the development of this technology for manufacturers.

Keywords: Fused deposition modeling, precision medicine, solid oral forms, quality by design, hot melt extrusion, 3D printed drugs

Table of contents

1	<i>Introduction</i>	5
2	<i>Search strategies</i>	7
3	<i>Distribution of studies and involvement of different actors around the world</i>	8
4	<i>Manufacturing of 3D solid oral form by FDM</i>	10
4.1	Printability of the filaments	27
4.2	Raw materials	28
4.3	Working temperatures	31
4.4	Storage	33
4.5	How to improve printing quality	33
4.6	Potential processing hazards	36
5	<i>Use of printlets in the futur</i>	37
5.1	Dosages and kinetics achieved	37
5.2	Strategy to modulate dosage and release kinetic	39
5.2.1	For HME-FDM and Impregnation-FDM.....	39
5.2.2	For Print and fill approach	42
5.3	New original properties through designs	43
5.4	Expected benefits from using FDM to print drugs	47
5.4.1	Drug development research	47
5.4.2	Precision medicine	47
5.4.3	Toward on demand medicine?	50
5.5	Place of FDM in the healthcare system	50
6	<i>The challenges of FDM 3D printing</i>	51
6.1	Control variability on computer aided design, slicers and printers	51
6.2	Quality by design	53
7	<i>Conclusion</i>	55
8	<i>Fundings</i>	56
9	<i>References</i>	56

Abbreviations used

ABS	Acrylonitrile Butadiene Styrene
API	Active Pharmaceutical Ingredient
ASA	AminoSalicylic Acid
CAD	Computer Aided Design
EC	Ethyl Cellulose
EMA	European Medicines Agency
FDA	Food and Drug Administration
FDM	Fused Deposition Modeling
GMP	Good Manufacturing Practice
HME	Hot Melt Extrusion
HPC	HydroxyPropyl Cellulose
HPMC	HydroxyPropyl MethylCellulose
HPMCAS	Hypromellose Acetate Succinate
ICH	International Council of Harmonization
PCL	PolyCaproLactone
PEG	PolyEthylene Glycol
PEO	PolyEthylene Oxide
PLA	PolyLactic Acid
PRISMA	Preferred Reporting Items for Systematic Reviews and Meta-Analyses
PVA	PolyVinyl Alcohol
PVP	PolyVinyl Pyrrolidone
QbD	Quality by Design
TEC	TriEthyl Citrate
TPU	Thermoplastic PolyUrethane
UFP	Ultra Fine Particles

UK	United Kingdom
USA	United State of America
VOCs	Volatile Organic Compounds

1 Introduction

We are living a deep change in our society due to digitization and computing power. A transition in the health sector is slowly taking place with a move from conventional medicine to precision medicine, also known as personalized medicine (1). Backed by powerful algorithms to interpret large amounts of data, the goal of precision medicine is to adapt the treatment of each individual with respect to its genomics, its environment and its lifestyle in order to maximize effectiveness and decrease the side effects of treatments (2,3). This approach is supported by health authorities such as the Food and Drug Administration (FDA) who provides a list of drugs associated with specific actions to be undertaken according to a list of biomarkers (4). Another example is provided by the *National Institute of Health* which founded in 2013 “ClinVar” an open centralized database to collect and improve the understanding on genomic variations and their implication for the patient (5).

Although precision medicine is highly concerned in choosing the right treatments for the right patients at the right time, precision dosing needs also to be considered (6). Optimal dose prediction models are being increasingly used (7,8), especially for particular populations such as children, pregnant women, obese, cancerous patient and elderly (9–14). The need to change current practices for dosage adjustment in these particular populations and the need to develop predictive models was pointed out in a workshop held in 2015 by the FDA, European Medicines Agency (EMA), academic and pharmaceutical industries (15). Indeed, drugs are typically initiated with standard doses that are usually defined by clinical trials in adults. For children, the doses are often simply modulated by weight or body surface area (16). For elderly, dosage often needs to be lower in accordance to their tolerance (17). And, there are many other factors that can lead to modulate dosages such as sex, genomics, interaction between drugs, food regimen, occurrence of an adverse effect, intercurrent disease, etc, which enhance the need of further developing precision medicine (6,10,12,18,19).

For instance, an online algorithm (www.warfarindosing.org) has been developed to adjusting the dose of Warfarin (20), a narrow therapeutic index anticoagulant, based on patient’s clinical and genotypic information. In the near future, there is no doubt that with the development of knowledge and increasingly powerful algorithms, doses

of drugs will be tailored to the needs of each individual. However, the problem is that currently, laboratories have limited means to adapt their drugs to the specific needs of individuals. Dry oral forms illustrate well the current situation, although it is one of the best routes of administration, especially for long-term therapies, they are one of the pharmaceutical forms lacking the most adaptability.

Additive manufacturing, also known as 3D printing technology, will conceivably disrupt the drug production methods in the years to come. The 3D printing technique is already highly developed in other sectors such as aerospace, electronic, automotive or consumer goods (21). In the pharmaceutical field, it firstly emerged for the production of customized medical devices and since 2014 it is being used also for the production of custom-made medicines (22). Fused deposition modeling is, among the additive manufacturing techniques used, the most investigated in the pharmaceutical environment due to its simplicity and lower cost (23–25) and it is particularly adapted to the production of solid oral forms (26).

Fused Deposition Modeling (FDM) technology patent fell into the public domain in 2009 (27) and it is as simple as a plastic filament being pushed into a heating head. At its contact, this filament softens to a semi-solid state which is deposited in regular thin layers on a bed by extrusion. Either the bed or the heating head moves in 3 dimensions during extrusion, depending on the printer model, allowing the juxtaposition of the layers to each other with great precision. When the next layer is deposited, the heat allows molecular bonding with the previous layer. Once cooled, the object benefits from the hardness of the plastics and can be removed from the tray.

This technology is able to produce easily objects with complex geometries from a digital design, without using molds or other conventional industrial techniques. It is important to highlight that no Good Manufacturing Practice (GMP) guidelines for medical FDM printing and for the production of pharmaceutical filaments have been yet established.

The primary objective of this scoping review is to explore by using a systematic research, how the FDM technology could be used to produce oral drugs with high degree of personalization. Thus, an overview on 3D machines, softwares and raw materials employed in pharmaceutical FDM is presented with particular focus on how FDM can enhance the tailoring of dose and release kinetics.

Finally, the deployment of this technology in modern healthcare society is discussed pointing out the need to introduce a Quality by Design (QbD) approach to facilitate the acceptance of tailored drugs produced by FDM-3D printing by the authorities.

2 Search strategies

Following the Preferred Reporting Items for Systematic Reviews and Meta-Analyses Statement criteria (PRISMA) used to perform systematic reviews; two bibliography methods were employed to get a maximum of articles directly related to the subject: a systematic research and a top-down bibliography. More details on the search strategy are presented in Supplemental Data 1. Our research strategy is schematically represented in Figure 1.

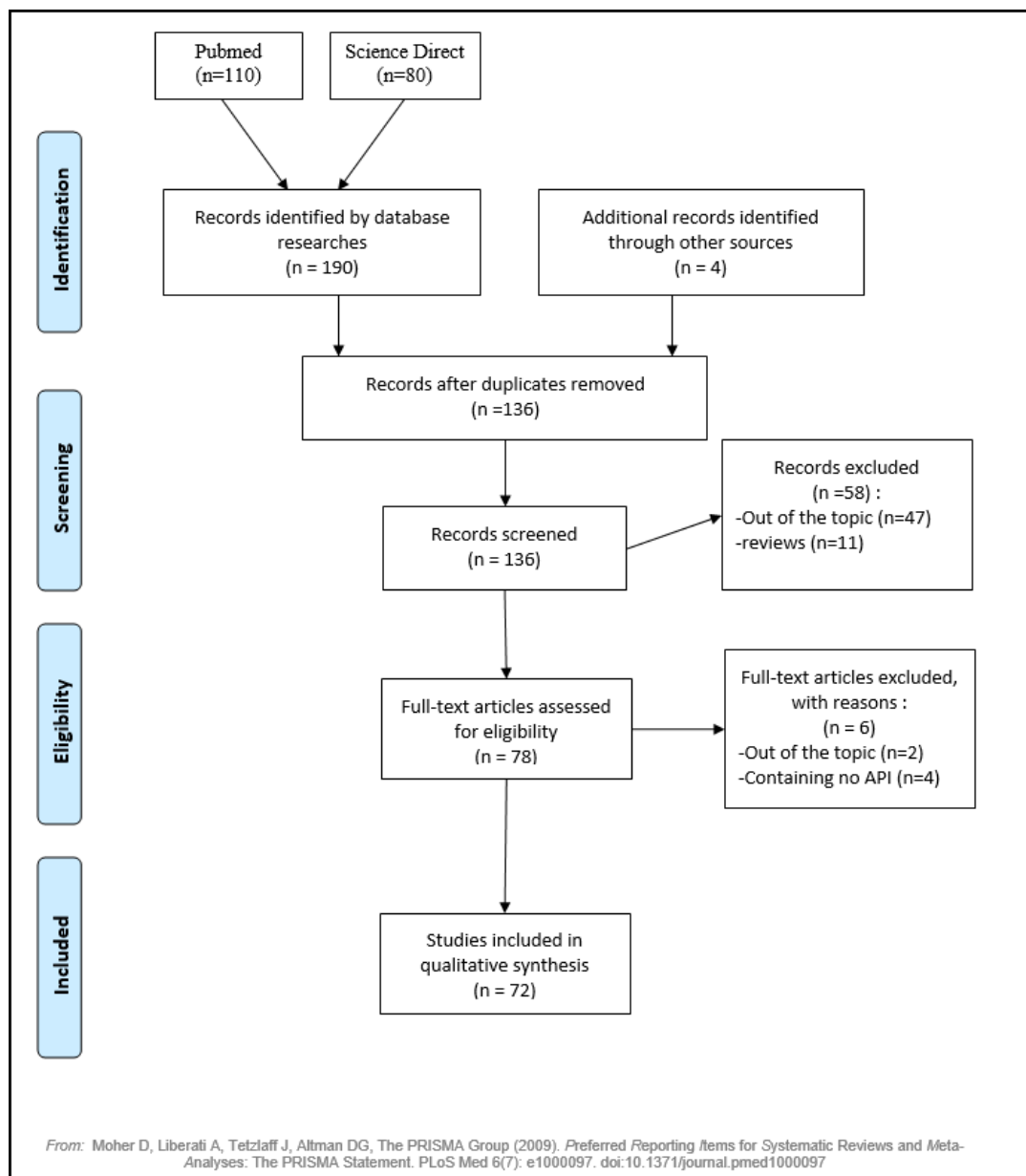

Figure 1. Flow chart indicating the number of articles found through the different phases of the systematic review according to the PRISMA Statement.

3 Distribution of studies and involvement of different actors around the world

In total, 72 articles were analyzed. From these, 70 articles were gathered from the databases Pubmed and Science Direct and 2 articles were added from the top-down bibliographic approach. The systematic research ended up in 2019. The objectives and main findings of included articles are presented in Supplemental Data 2.

It was observed that FDM studies are unevenly performed around the world. Regarding the country of affiliation of the first author, the United Kingdom (UK) leads

the production of articles regarding this subject with 27 articles (37.5%) published so far. It is followed by the United States of America (USA) (11%), China (7%) and Italy (7%). It is worth noting that the UK has the largest number of universities (6 in total) working on this subject which provides a prolific network between research teams working on the topic.

Since the very beginning of this research topic in 2014, it can be observed that private actors are very invested on this theme of research. Among the private actors, it can be distinguished the start-ups as FabRx (co-founded by A. Goyanes) or Multiply labs which were founded with the aim to create solid oral forms with 3D printers or big pharma companies such as GlaxoSmithKline, Takeda GmbH, Zentiva or Astellas. Other private companies are also involved supplying an expertise or analysis role. For instance, raising 3D start-up companies participated in the publication of 36.1% of the articles to date, mainly through partnership with universities. And Merck company published two fully private articles. From 2017, these private and public partnerships have both diversified and intensified, representing the recent popularity of these technologies for business opportunities.

Another parameter showing the rising interest on this topic is the increase of FDM publications over years, as seen in Figure 2. While in 2014 and 2015, all the published articles were issued from two research teams based in the UK which were widely supported by private actors. From 2016, the interest for this technology has spread over the world and involved new research teams. Only, between 2016 and 2018, the number of articles published has been multiplied by three. One explanation for this rapid growth lies in the fact that FDM is a low-cost technology, easy to handle and taking up little space which is compatible with the research community. Another one is that technology opens new and interesting opportunities to tailor drugs on individual characteristics, needs and preferences and could allow to move away from the 'one-size-fits-all' era (28).

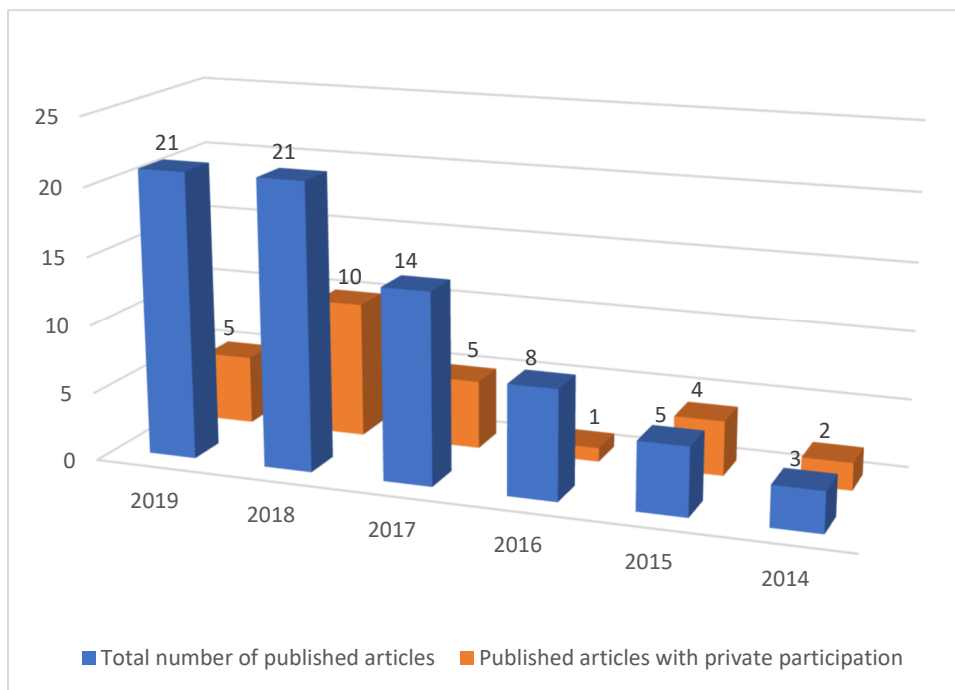

Figure 2. Evolution of the number of FDM articles published per year.

4 Manufacturing of 3D solid oral form by FDM

Among the reviewed articles, three different approaches to incorporate the Active Pharmaceutical Ingredient (API) into the 3D printed object have been identified.

The first API incorporation strategy, named as *"Impregnation-FDM"*, consists in soaking a filament in a solution or a dispersion of an API during several hours to days. Once the impregnation is done, the filament is dried in an oven until stable weight is obtained and stored in a vacuum desiccator. Then the API-loaded filament is processed through the printer as raw material to achieve an oral dosage medicine. A diagram summarizing the *"Impregnation-FDM"* concept is presented in Figure 3.

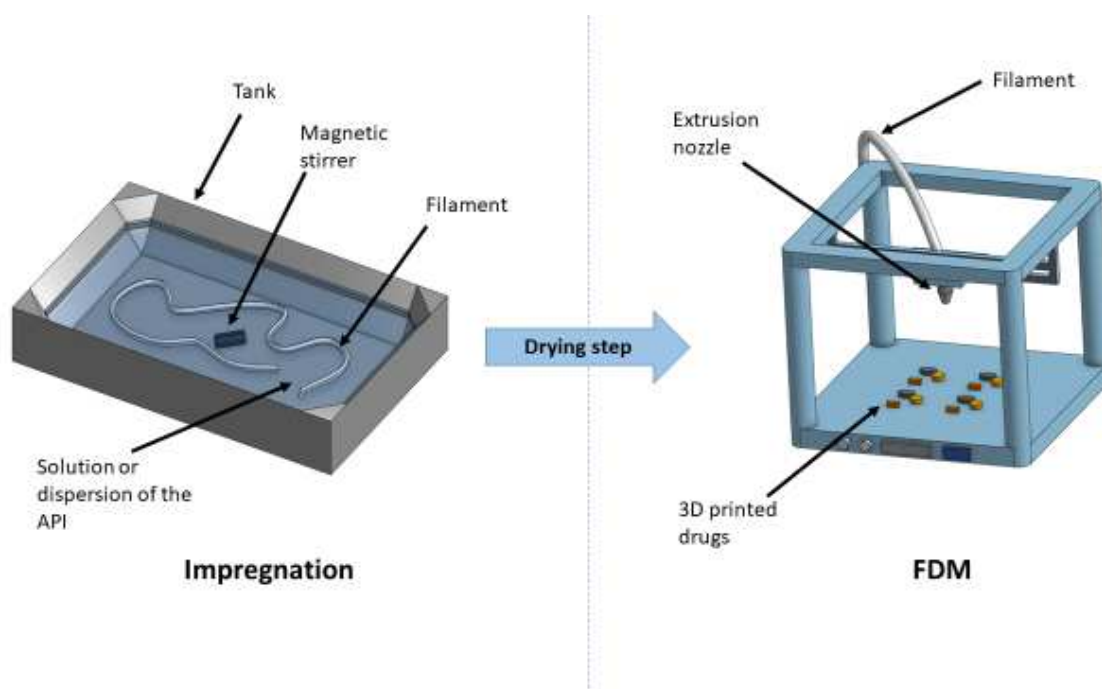

Figure 3. Schematic use of Impregnation-FDM to print drugs.

This approach was firstly reported in 2014 (22) and although it is considered a low cost and reduced time formulation method; the API loading achieved is quite low ranging from 0.063 to 2.07% w/w (29,30). Higher drug loadings are difficult to reach since solvent choice is limited and impregnation process can alter the surface of the filament rendering it unfit for printing (30,31). Although other strategies have been developed such as directly loading the API on the printed oral form instead than into the filament, not considerable improvements have been obtained. Consequently, only 8.3 % of the reviewed studies include this process (32). A summary of raw materials, manufacturing process, dose and kinetics of the produced solid oral form is presented in Table 1.

API	Polymer used	Other materials added by Hot Melt Extrusion (HME)	Solvent used	Incubation time	% drug loading	Printing temperature	Yielded Kinetics	Mean dose of API	Reference
4-AminoSalicylic Acid (ASA) 5-ASA	PolyVinyl Alcohol (PVA)	-	Ethanol	24 h	4-ASA: 0.236% 5-ASA: 0.063%	210°C	Sustained release	Calculated: 4-ASA: 0.6-0.74 mg 5-ASA: 0.16 to 0.2 mg	(29)
Curcumin	PVA	-	Ethanol	24 h	Calculated: 0.175%	140-250°C	Sustained release	Cylindrical tablet containing Calculated: 0.114 mg – 0.99 mg	(33)
Deflazacort	Eudragit® RL PolyCaproLactone (PCL)	Mannitol Microcrystalline cellulose PolyEthylene Glycol (PEG) 6000 Triethyl acetate	Acetone	4-24 h at room temperature – with printed object	Loading directly through the tablet: 0.062-0.620%	95-170°C according to the (API-Free-) polymer used	Sustained release	0.193 mg- 0.510 mg according to the formulation used	(32)
Fluorescein	PVA	-	Ethanol	24 h	0.29%	220°C	Sustained release	Calculated: 0.6-0.82 mg	(34)
Metformin	PVA	-	Ethanol / Water	72h	2.07%	205°C	Sustained release	4.2-4.8 mg	(30)
Prednisolone	PVA	-	Methanol	24 h	1.9%	230-250°C	Sustained release	Between 2-10 mg	(31)

Table 1. Synthesis of solid oral forms produced by Impregnation-FDM. % of drug loading is expressed in w/w. Mean dose of API and kinetics listed are those obtained on the final oral form.

The second strategy can be summarized as a “*Print and Fill*” process. It consists in printing an empty shell and filling it with API in powder or liquid form. The shell is made of thermoplastic filaments that have the property to control the dissolution kinetics of the final form. Printing and filling steps can be either simultaneous or sequential. In the first case, filling and shell printing are made at the same time which can be compared with the production of soft capsules (35). In the sequential case, the printing is paused after a partial shell has been printed in order to perform the filling step. Once filled, the device is completed and closed by resuming the shell printing (35,36). Another possibility avoiding any pause during printing consists to print the device in parts which will be clipped after filling step (37). In most studies, the filling step is done manually, in particular in the case of powder filling. Otherwise it can be integrated into the print file with a modified printer to be automatic (36,38). An illustration of “*Print and Fill*” technique is given in Figure 4.

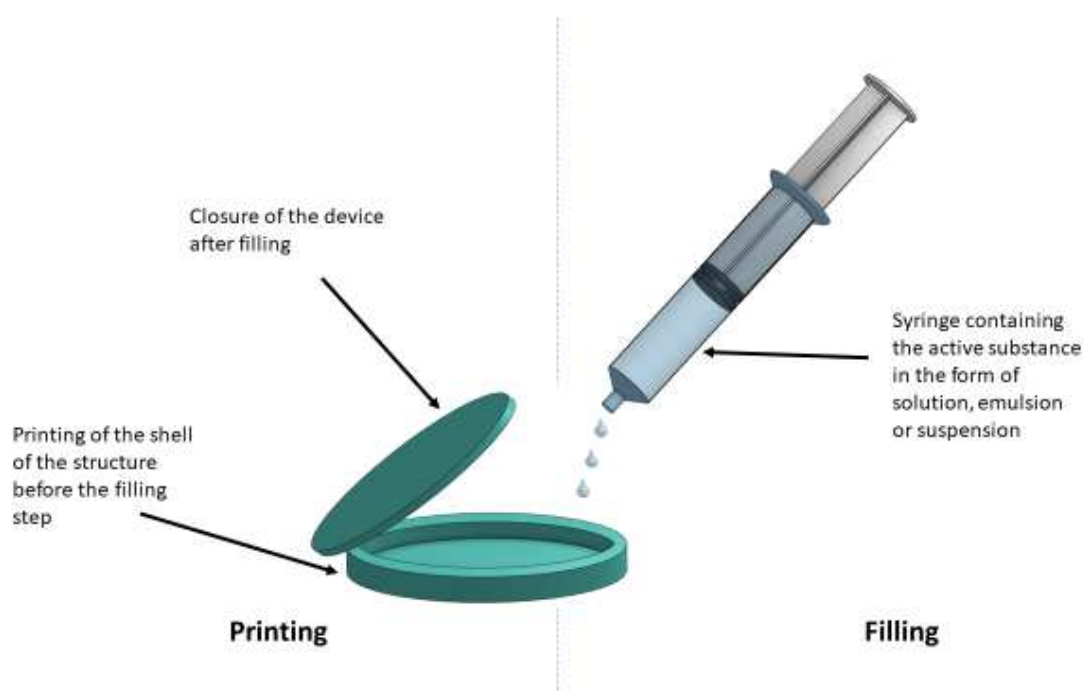

Figure 4. *Print and Fill* strategy. In this example, the device is locked by clipping the cap to the bottom after filling step.

Among all articles, 20.8 % employed “Print and fill” technique to produce oral dosage forms. Raw materials, API incorporation methods, shape of the final solid oral form and mean doses yielded by Print and Fill are summarized in Table 2.

API	API incorporation method	Bulk Material for the shell	Shape	Release Kinetics	Mean dose of API in final oral form	Reference
¹⁸ F-Fluorodeoxyglucose	Manually filled	Kollicoat® IR HydroxyPropyl Cellulose (HPC) Ethylcellulose Hypromellose Acetate Succinate (HPMCAS)	Capsule	Immediate and sustained release	5 µL of ¹⁸ F-fluorodeoxyglucose with an activity of 3 MBq	(39)
5-Fluorouracil	Manually filled	Eudragit® L Eudragit® S PolyLactic Acid (PLA)	Cylindrical tablet with smoothed edges	Sustained release	-	(40)
Paracetamol	Manually filled	Kollicoat® IR HydroxyPropyl MethylCellulose (HPMC) HPMCAS	Two half shells of a capsule that can be clipped with a joint delimiting the device in two hollow compartments	Delayed release	80 mg	(37)
Paracetamol	Manually filled	Eudragit® RS	Hollow capsule with various wall thicknesses	Delayed release	0.48 mg	(41)
Paracetamol	Manually filled	HPC	A hollow capsule	Delayed release	80 mg	(42)
Acyclovir	Manually filled	PLA	Windowed floating capsules	Sustained release	100 mg	(43)
Paracetamol	Manually filled	PVA	A sphere with internal cavities in shape of cylinder, horn or reversed horn.	Sustained release	-	(44)
Carbamazepine Saquinavir Halofantrine	Manually filled	PVA, PLA	Cylindrical structure with an inner and an outer chamber	Sustained release	- - -	(45)
Dronedarone hydrochloride Ascorbic acid	Manually filled	PVA	Super-H capsules or Can-capsules with inner compartments	Sustained release and delayed release	200 mg	(46)
Lamivudine	Filled by the printer syringe for liquid dosages. Manually	PVA	Cylindrical hollow capsule with	Delayed	40 mg	(38)

Merck-property API.	filled for solid granules or powder.		internal scaffold	release		
Metformin	Filled by the printer syringe	PVA	Cylindrical hollow capsule with internal scaffold	Not evaluated	-	(47)
Riboflavin	Manually filled	PLA	Floating cylindrical tablet with: -a hollow chamber -presence of 0,1 or 2 nets -a self-lock to close the device	Sustained release	20 mg	(48)
Riboflavin	Manually filled	Eudragit® L PLA PEG	Capsules with modified head and body parts	Delayed release	9 mg	(49)
Theophylline Dipyridamole	Filled by the printer syringe	Eudragit® EPO (with plasticiser and filler) Eudragit® RL (with plasticiser and filler)	A hollow capsule	Immediate and Sustained release	Theophylline: undetermined Dipyridamole: 1.4-6.4 mg	(35)
Theophylline	Filled by the printer syringe	PLA Eudragit® FS30D (bring by injection volume filling)	A partially hollow tablet with an incomplete infill	Sustained release	Theophylline: 4 mg	(36)

Table 2. Presentation of solid oral forms produced by Print and Fill approach.

The third strategy combines Hot Melt Extrusion and FDM and it is therefore called “HME-FDM”. Used for the first time in 2015 (50), this strategy quickly became paramount and represents nowadays the most used method among all studies (70.8 %). In this technique, the active ingredient and excipients are added in the form of powder or pellets and are mixed either by a single or a twin screw conveyor to be co-extruded as an API-loaded filament. For pharmaceutical purposes, a gravimetric feeder is usually preferred to volumetric feeder as it provides higher accuracy (51). Also, a twin screw extruder is generally preferred to a single screw extruder for pharmaceutical formulations due to its higher mixing capability and lower tendency to overheat (52). A balance between input feed rate and screw speed must be found in order to obtain a uniform filament. The mixing temperature used is beyond the glass transition temperature and below the degradation temperature of the mixture to ensure good melt viscosity and homogeneisation between the API and excipients (51). Then, the extruded filament undergoes a cooling step to solidify before serving as raw material in the following printing step. HME paired with FDM is illustrated in Figure 5.

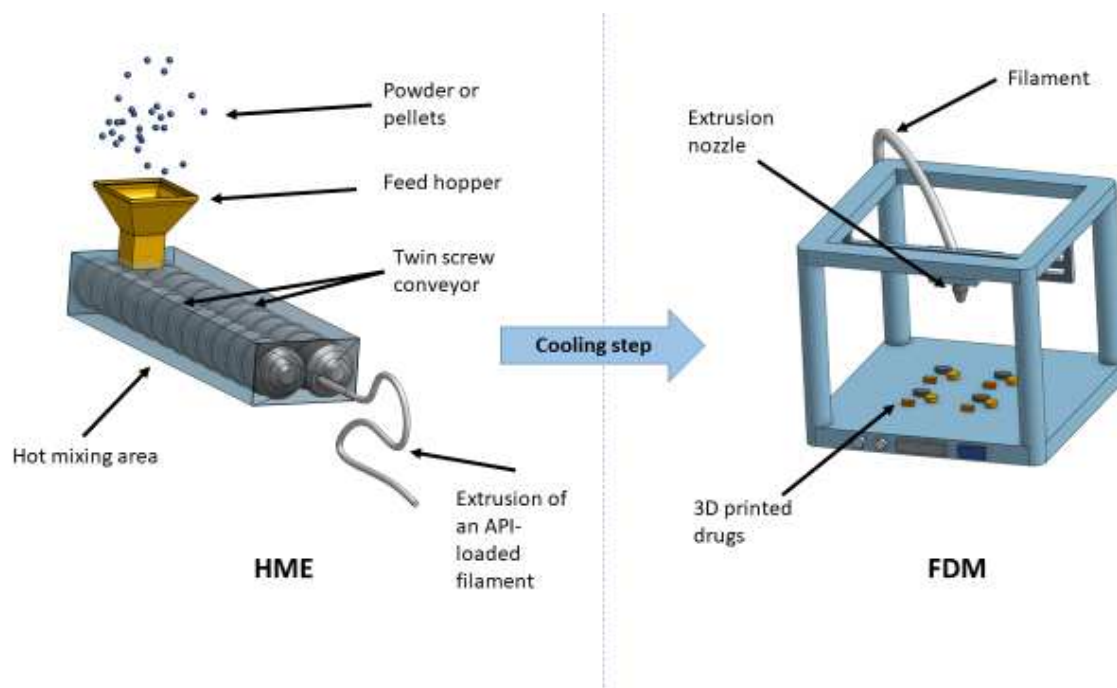

Figure 5. Schema of HME paired with FDM for drug printing.

In contrast to impregnation technique, API-loading of the filament is between 1 and 50%, with a median value of 10%. *HME-FDM* can promote API amorphization since APIs undergo two thermal spikes during this process: a first one during extrusion, and a second one while printing. On the other hand, the necessary material for HME-FDM makes this technique more expensive than the previous two. Raw materials, type of extruders, working temperatures, shape of the final oral forms and mean doses obtained by HME-FDM are summarized in Table 3.

API (theoretical % w/w in filament)	Polymer(s)	Other excipients	Type of extruder	Maximal temperature used in hot melt extrusion	Printing temperature	Shape of the printed object	Kinetics	Mean theoretical or content dose in the achieved medicine	Reference
Paracetamol (30%)	HPC EC HPMC Soluplus® Eudragit® L100	Kollidon® CL-F	Twin screw	140-180°C	200°C	Cylindrical tablets	Sustained release	122–132 mg	(53)
Acetylsalicylic acid (5-15%)	PCL	-	Twin screw	100°C	100-120°C	Square films	Sustained release	Undetermined	(54)
Allopurinol (10%)	PVA	Glycerol	Twin screw	175°C	200°C	Cylindrical helix shape	Sustained release	56 mg	(55)
Aripiprazole (not specified)	PVA	-	Single screw	172°C	190°C	Rectangular films	Immediate release	3.3 mg by 6 cm ² of films	(56)
Baclofen (10%)	PVA	Sorbitol	Twin screw	160°C	170-190°C	Minicaplet	Sustained release	5.8–11.8 mg	(57)

Budesonide (2.3%) Diclofenac (20%) Theophylline (10%)	PolyVinyl Pyrrolidone (PVP)	TriEthyl Citrate (TEC) Talc Tribasic phosphate sodium	Twin screw	100°C	185°C for shell (API- free) 110°C for core of the tablet	Oblong caplet	Delayed release	Budesonide: 3 mg Diclofenac: 25 mg Theophylline: undetermined	(58)
Budesonide (5%)	PVA	-	Single screw	170°C	190°C	Caplet	Sustained release	9 mg	(59)
Caffeine (5%)	Kollidon® VA64 PCL Polyethylene oxide (PEO)	Kolliphor® P188	Twin screw	140°C	150°C	Cylindrical tablet	Sustained release	Undetermined	(60)
Caffeine (5%)	Kollidon® VA64 PCL PEO	-	Twin screw	140°C	150°C	Cylindrical tablets	Sustained release	11-27 mg	(61)
Caffeine (5-10%) Paracetamol (5-10%)	PVA	-	Single screw	180°C	200°C	Capsule shape	Sustained release	11-27 mg	(62)
Calcein (Unspecified)	PVA (unknown) PLA as water insoluble coating agent	Unknown	Twin screw	210°C	190°C	Cylindrical with various internal arrangement	Sustained release	Undetermined	(63)

Carvedilol	HPMC	Kolliphor® TPGS	Twin	130°C	135-200°C	Cylindrical	Sustained	62-67 mg	(64)
------------	------	-----------------	------	-------	-----------	-------------	-----------	----------	------

(20%)	Kollidon® SR HPC Eudragit® EPO		screw			tablets	release		
Ciprofloxacin (10-35%)	PVA	Dibutyl sebacate	Single screw	175°C	195°C	Cylindrical tablet	Sustained release	86-111 mg	(65)
Deliberately unspecified (10-40%)	Blend of two polymers deliberately unspecified	Deliberately unspecified	Co- rotating twin screw	140°C	145°C	Cylindrical with internal structure rearrangement	Sustained release	Undetermined	(66)
Domperidone (10%)	HPC	Barium sulfate	Twin screw	145-150°C	210°C	Cylindrical hollow tablet	Intragastric sustained release	18-24 mg	(67)
Dronedarone (10%)	PVA	PEG	Single screw	170°C	200°C	Capsule shaped	Sustained release	100 mg	(68)
Felodipine (10%)	Eudragit® EPO Soluplus® PVA	Tween 80 PEG 4000 PEO	Twin screw	100-130°C	150°C	A thin cylindrical shape as a disc	Sustained release and immediate release	5.5-6.1 mg	(69)
Furosemide (30%)	Kollocoat® IR PEO HPMCAS Eudragit® L HPC HPMC PVA Soluplus® EC Eudragit® RL	Glycerol PEG 400 PEG 8000 TEC	Twin screw	65-190°C	160-225°C	Thin discs	Immediate, delayed and sustained release	Undetermined	(70)

Glipizide (2.5-5%)	PVA	-	Single screw	180°C	195°C	A thinner and a larger cylindrical tablet fit together to form a double chamber dosage form	Sustained release	16 mg	(71)
Haloperidol (10-20%)	Kollidon® VA64 Affinisol Kollicoat® IR HPMCAS	-	Twin screw	170°C	210°C	Cylindrical tablets	Immediate release	11.5-13 mg	(72)
Hydrochlorothiazide (12.5%)	Eudragit® E	Triethyl citrate Tri-Calcium phosphate Sodium starch glycolate Crosslinked PVP Croscarmellose sodium	Twin screw	100°C	135°C	Perforated oblong caplet	Immediate release	67-80 mg	(73)
Hydrochlorothiazide (25%) Enalapril maleate (15%)	Eudragit® EPO	Tri calcium phosphate Triethyl citrate	Twin screw	100°C	135°C	Bilayer caplet	Immediate release	Hydrochlorothiazide: 12.5-25 mg Enalapril: 5-20 mg	(74)
Hydrochlorothiazide (6%)	PVA	Mannitol	Single screw	170°C	200°C	Donuts' shape	Sustained release	25 mg	(75)

Ibuprofen	Ethylcellulose	HPMC	Twin	100-120°C	170-186°C	Cylindrical tablet open	Sustained	61.3-73.1 mg	(76)
-----------	----------------	------	------	-----------	-----------	----------------------------	-----------	--------------	------

(16-24%)		Xanthane gum Sodium Alginate Polyvinyl alcohol (PVA)	screw			on an internal scaffolding structure	release		
Indomethacin (20%)	HPMCAS	PEG 6000	Twin screw	140°C	165°C	“Candy-like” with various shape	Immediate release	25 mg for each shape	(77)
Isoniazid (30%)	HPC HPMC PEO Eudragit® RL, RS and L	Kolliphor® TPGS TEC	Twin screw	120-155°C	165-195°C	Cylindrical tablets	Immediate and sustained release	18-71 mg	(78)
Itraconazole (20%)	HPC PVP	-	Single screw	135°C	185°C	Cylindrical tablets	Sustained release	33-80 mg	(79)
Lisinopril (20%) Amlodipine (10%) Indapamide (5%) Rosuvastatin (20%)	PVA	Sorbitol Titanium dioxide Water	Twin screw	90°C	150°C	Capsule shape	Immediate and sustained release	Lisinopril: 10 mg Amlodipine: 5 mg Indapamide: 2.5 mg Rosuvastatin: 10 mg	(80)
Lovastatin (5%) Hydrochlorothiazide (5%)	PCL Kollidon® VA64	PEO	Twin screw	140°C	160°C	A flat bilayer tablet	Sustained release	Undetermined	(81)
Metformin (5-15%)	PVA	Sorbitol	Twin screw	170°C	200°C	An egg- shaped tablet	Immediate release	Undetermined	(82)

Metformin (50%) Glimepiride (2%)	Eudragit® RL PVA	PEG TEC PLA Citric acid Mannitol Magnesium stereate	Single and twin screw	140-157°C	170-205°C	Cylindrical shape with rounded edges	Combination of sustained release and immediate release	500 mg metformin 2 mg glimepiride	(83)
Metformin (20-60%) Theophylline (20-60%)	Several grade of Thermoplastic PolyUrethane (TPU)	-	Co- rotating twin screw	100-180°C	120-180°C	Cylindrical tablet	Sustained release	Theophylline: 158-239 mg Metformin: 189-269 mg	(84)
Pantoprazole (10%)	PEG 6000 PVP K12	TEC	Single and twin screw	51-55°C for core filament 47-131°C for coat filament	54-79°C for tablet core printing 58-165°C for coating	Cylindrical shape for internal core and external coating	Sustained release	18.3 mg	(85)
Pantoprazole (5-20%)	PEG 6000 PEG 20000 Poloxamer 407 PVP Kollidon® VA64 Kollicoat® IR PEO	Triethyl acetate Kollidon® CL Sodium polyacrylate	Single screw	41-145°C	54-87°C	Cylindric	Immediate release	20 mg	(86)
Paracetamol (10%)	HPMC Soluplus®	-	Twin screw	160°C	200°C	Cylindrical shape	Sustained release	17-43 mg	(87)

Paracetamol (20-42%) Ibuprofen (20-40%)	PVA PEO	Croscarmellose sodium Sodium Starch Glycolate Sodium Lauryl sulfate	Single screw	130°C for PVA 60°C for PEO	190°C for PVA 165°C for PEO	Circular and square films	Immediate release	8.5-27 mg	(88)
Paracetamo (5%)	PVA	-	Single screw	180°C	180°C	Cube- pyramid- cylinder- sphere-torus	Sustained release	4.9-25.5 mg	(89)
Paracetamol (5-10%) Caffeine (5-10%)	PVA	-	Single screw	180°C	200°C	Caplet shape	Sustained release	Paracetamol: 16 mg-29 mg Caffeine: 14-30 mg	(90)
Paracetamol (5-50%)	HPMCAS	Methylparaben Magnesium stearate	Single screw	80-110°C	180-190°C	Cylindrical tablet	Sustained release	Undetermined	(91)
Paracetamol (5-50%)	HPMC	-	Twin screw	100-180°C	190°C	Cylinder Slotted grid Slotted grid with cap Slotted grid extended	Sustained release	16-99 mg	(92)
Pregabalin (50%)	HPMCAS	PEG 400	Twin screw	125°C	180°C	Cylindrical tablets without top and bottom shells.	Sustained release	168-335 mg	(93)

Pramipexole (0.7%)	PEO Eudragit® EPO	-	Single screw	120-130°C	160-175°C	Cylindrical tablets	Immediate release	1 mg	(94)
Ramipril (3%) 4-ASA (3%)	Kollidon® VA64 Kollidon® 12 PF	PEG 1500 Mannitol Magnesium carbonate	Single screw	65-70°C	90°C	Cylindrical tablet	Immediate release	8.8 mg	(95)
Theophylline (10%) Dipyridamole (10%)	PVP	TEC Talc	Twin screw	100°C	110°C	Oblong caplet	Immediate release	11-12 mg for each API	(96)
Theophylline (10%)	HPC Eudragit® RL	PEG	Twin screw	110°C	195°C	Caplet	Sustained release	62-80 mg	(97)
Theophylline (12.5%) Prednisolone (12.5%) Captopril (12.5%) 5-ASA (12.5%)	Eudragit® EPO	Tri calcium phosphate, TEC, talc, lactose, microcrystalline cellulose	Twin screw	100°C	135°C	Caplet	Immediate release	24-25 mg for each API	(98)
Theophylline (30%)	Eudragit® RL	Stearic acid PEG 4000 PEG 300 Colloidal anhydrous silica	Twin screw	140-180°C	180°C	Caplet without solid layer at the top of the caplet	Sustained release	216-310 mg	(99)

Theophylline (30%)	PEO	PEG	Twin screw	60-80°C	105-145°C	Caplet and radiator shaped tablet	Sustained release and immediate release	51-80 mg	(100)
Theophylline (50%)	Eudragit® RL Eudragit® RS Eudragit® E HPC	TEC	Twin screw	125-130°C	140-170°C	Oblong caplet	Immediate release and Sustained release	Varying between 60-300 mg	(50)
Theophylline (50%)	HPC	Triacetin Sodium starch glycolate Croscarmellose sodium Crospovidone	Twin screw	120°C	Not precised	Particular caplet with 9 repeating units and 8 gaps.	Immediate release	158-171 mg	(101)
Warfarin (1%)	Eudragit® EPO	TEC Tri-calcium phosphate	Twin screw	100°C	135°C	Capsule shape	Immediate release	0.5-3 mg	(102)

Table 3. Summary of solid oral forms produced by HME-FDM

4.1 Printability of the filaments

One of the common difficulties found in most FDM studies is to define the expected characteristics of the filament in order to be printable. In fact, FDM needs filaments with rheological and mechanical properties more restrictive than HME and it is common that a filament extruded by HME is not adapted for FDM-3D printing (69,76).

According to Fuenmayor, printing process can be divided into three distinct zones: feeding, hot and deposition zone (60). In each zone, various constraints are applied to the filament and these mechanical forces are schematized in Figure 6. Filament brittleness is one of the first causes of printing defect: to sustain the pinching force exerted by the gear wheels, several studies found that the breaking distance of the filament by three point bending flexural test should be $>1\text{mm}-1.5\text{ mm}$ with breaking stress $>2941-3126\text{g/mm}^2$.(53,78). To be driven to the hot end without bending or squeezing and to demonstrate sufficient column strength to push out the molten filament, filaments must exhibit a good balance between ductility and stiffness while showing appropriate resistance to traction (64,97).

Besides mechanical properties, the rheological property of the filament is also important as it affects melt flow index and the behavior of the polymer after extrusion (coalescence of layers, and ability to solidify). A melt flow rate around $10\text{g}/10\text{min}$ through a heated capillary (ISO 1133) has been identified as a threshold to achieve acceptable 3D printing quality with PLA (103) and this value has also been found for other pharmaceutical materials such as a blend of PCL, PEO and Kollidon® VA64 (61). Shear thinning behavior of polymers seems to be also favorable to FDM-3D printing. It has been demonstrated to play a role in both, decreasing viscosity in the hot end, and enabling a quick solidification when cooling in the deposition zone (104). More investigations about printability prediction are still needed nowadays as to date, the essential of the filament formulation is made empirically by trial and error approach (60,83,93). The identification of other characteristics and related threshold are necessary to accelerate the development of this technology.

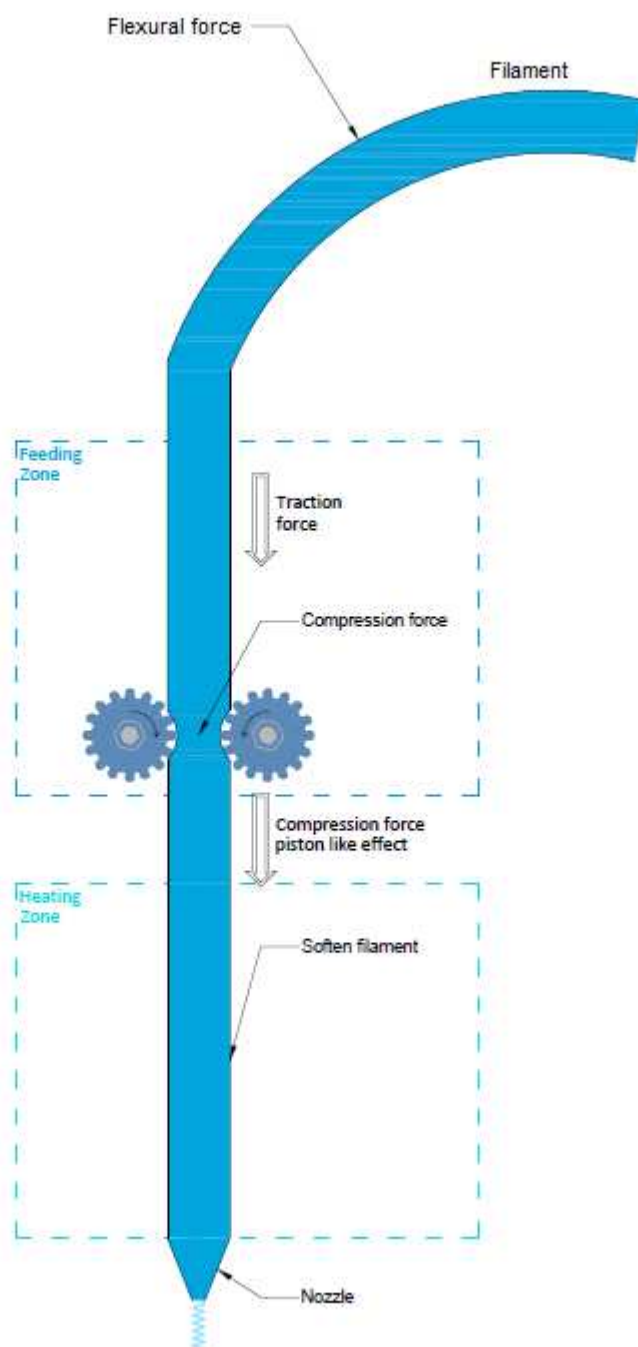

Figure 6. Schema showing the mechanical forces exerted on the filament during printing.

4.2 Raw materials

In total, among the 72 analysed studies, a very large range of active ingredients (47) have already been formulated through FDM, from Biopharmaceutics Classification System I to IV proving the ability of FDM to be extended to a large variety of API. Fewer numbers of polymers are counted (22) including commercially available polymers such as PVA, PLA and TPU; pharmaceutical excipient-based formulations

such as simple polymers derived from cellulose (HPMC, HPMCAS, HPC...); more complex copolymers like Eudragit® or Kollidon® VA64.

The choice of the main polymer is crucial and responsible of the main rheological and mechanical properties of the filament (64). Some polymers have been recognized more suitable for FDM (PEO, HPMCAS and PVA), especially regarding their feedability, showing correct stiffness and rheological behavior. Others such as Eudragit® EPO, Soluplus® and Kollidon® VA64, require large quantities of excipient to bear printing constraints and improve the quality of printed object (105). For example, the addition of components with plasticizer effect tends to decrease the melting temperature (changes in rheological properties), and also decreases the stiffness of the filament (changes in mechanical properties) (76). So, it is important to find the appropriate level of plasticization since it can make the filament too soft and unfit for printing (105). Note that APIs themselves often have a plasticizing effect when embedded in a filament (58).

Also, the release profile of the final oral form is mainly governed by the choice of the polymer matrix: for water-soluble and swellable polymers, the drug release depends on both, drug diffusion and polymer surface erosion (62). For insoluble polymers such as EC or PCL, the release kinetics tends to be driven by the drug diffusion mechanism.

Polymers can be classified according to their rate of release into water:

- Immediate release: Eudragit® EPO, Kollicoat® IR, PEO, Kollidon® VA64, PVP and PEG.
- Sustained release: PVA, Eudragit® RL, PCL, PLA, HPMC, HPC, TPU, Soluplus®.
- Delayed release: HPMCAS, Eudragit® L and Eudragit® S.

PVA is a versatile material as immediate release can be obtained with thin films of PVA (56), delayed release is yielded by producing capsules with a thick API-free PVA shell (38), and sustained release has been procured through various tablet design as sphere, torus or cylinder (89). As a result of its release versatility and its inherent suitability to sustain FDM, PVA is the most employed polymer for FDM 3D printing, as it is involved in 35 % studies. More, in Impregnation-FDM approach, except one study which used impregnation after printing step on the final form of its devices

made of Eudragit® RL and PCL (32), all the other studies used PVA as it is commercially available filament.

The polymer grade can also have an impact on the release rate. For instance, fast dissolving oral films made of PEO 100 kDa showed faster disintegration times than oral films of the same formulation with PEO 200kDa (88). It is important to note the addition of a disintegrant excipient did not show an acceleration of the release kinetics of the polymer matrices employed by FDM, and sometimes even had the opposite effect (73,101). But, these results could be polymer dependent and need further investigation.

Besides thermoplastic polymers, other excipients have been used within filament formulations. Five major families of excipients have been identified, whose roles stand out as follows:

- **Plasticizers**, aiming to reduce the melting point of the filaments and to allow printing at a lower temperature. For example, tween 80 (69), sorbitol (57), PEO (60,81), stearic acid (99) or PEG (77,83)
- **Fillers**, materials used to densify filaments which possess too flexible mechanical properties. For instance, talc (35,58), tri calcium phosphate (98), tribasic phosphate sodium (58).
- **Lubricants**, allowing a better rheology and facilitating the passage in the nozzle of the printer: magnesium stearate (39,91), calcium stearate (83), anhydrous colloidal silica (99) or PEG (32).
- **Release modifiers**: sodium alginate, xanthan gum (76), microcrystalline cellulose (32), mannitol (32), sodium lauryl sulfate (88). And disintegrants or super-disintegrants such as croscarmellose sodium, sodium starch glycolate or crosslinked PVP (88).
- **Others**: magnesium carbonate used as a stabilizer protecting the active ingredient from oxidation and hydrolysis (95).

It is important to note that excipient functionality can be different between FDM and traditional manufacturing processes such as direct compression. For example, stearic acid typically employed as a lubricant in compression, performs a plasticizer role when embedded in a filament with Eudragit® RL and theophylline (99). Also,

excipients could combine various roles within a formulation. For instance, sorbitol exhibited both lubricant and plasticizer effect when compounded with PVA and baclofen (57). Due to potential interactions between the different filament components which can cause unexpected properties and performances; further research would be needed on the effect of common excipients (fillers, release modifiers, lubricants...) in filament formulation.

4.3 Working temperatures

Another important effect to take into consideration during the printing process is the potential denaturation of the active ingredient and excipients into toxic degradation products (29). Most of API are heat-sensitive; their degradation is ruled by Arrhenius' law, with the rapport time (t) and Temperature (T) being critical.

Mainly there are two sensitive zones in the printer where the API can be exposed to high temperatures: the extrusion nozzle and the bed. It is important to point that while materials in the nozzle are exposed to high temperatures for a short period of time of a few seconds, in the bed this time can be much longer and can last several minutes.

Based on this, every printing parameter affecting the mean residence time of the filament within the printer must be considered with attention, such as printing and travelling speed, distance between unit to print and any pause during printing. For example, Ilyés *et al.* have determined that printing speed must be over 30mm/s in order to neglect the effect of degradation of carvedilol by heat, and to obtain an impurity level in accordance with the European Pharmacopoeia (64).

For printing temperatures between 170-250°C, most conventional polymers for 3D printing such as PVA, PLA or Acrylonitrile Butadiene Styrene (ABS) show their ideal rheological behavior. However, at these high temperatures, few active ingredients are heat-resistant enough. Among these APIs can be quoted: hydrochlorothiazide (75), mésalazine (5-ASA) (29), prednisolone (31), caffeine (90), paracetamol, glimepiride and metformin (83), which were printed without significant degradation.

Intermediate temperatures between 100 and 170 °C are the most common temperature range employed with home-made filaments based on pharmaceutical

polymers extruded by HME. These temperatures usually prevent the degradation of most APIs and also some polymeric excipients, like Eudragit® RL (83).

Below 100°C, even thermosensitive active ingredients such as Ramipril or Pantoprazole are not degraded. On the downside, these working temperatures are difficult to reach and only five studies have been reported under these conditions (3 in 2018 and 2 in 2019). The choice of polymer to achieve these low printing temperatures is paramount. To date, there are 7 polymers fulfilling this objective: two based on PolyVinyl Pyrrolidone (PVP K12 and PVP-VA64), three based of polyethyleneglycol (PEG 6000, PEG 20000 KDa and sulfonated PEG), a copolymer of polypropylene glycol and polyethylene glycol (Poloxamer 407), and finally PCL (54,85,86,95). To note that with PEG 6000 a minimal printing temperature of 54°C was successfully reached (85).

In the other hand, heat used by FDM while extruding can be an asset to increase the dissolution of drugs: By comparing the dissolution kinetics of films produced by FDM with traditional casting methods, Jamróz *et al.*, found that despite a slightly slower disintegration kinetics for the films produced by FDM (43s vs 38s), the dissolution kinetics were largely favorable for films produced by FDM. Indeed, they obtained 95% dissolution in 15 min for FDM-films versus 75% in the same time for casted films. This difference was explained by the fact that in the case of HME-FDM, the drug was present in an amorphous state, while in the case of casted films, the drug was present as a mixture of amorphous and crystalline state. Since the model drug used, aripiprazole, is naturally poorly soluble in water, this difference in crystallinity has a strong impact on the dissolution rate (56). In addition, the successive use of HME and FDM, two techniques using heat, can secure and complete this change of state to the amorphous form (64). Indeed, in the analyzed studies, most of the API used by HME-FDM underwent temperature driven amorphization.

It is important to clarify that the transition to the amorphous state within the matrix is dependent on the percentage of active ingredient added in the formulation. For instance, the incorporation of 5% of paracetamol in a HPMCAS filament allowed the production of tablets in which the paracetamol was in an amorphous state. While by the same process, the incorporation of 50% paracetamol in HPMCAS filament showed a semi-crystalline patterns characteristic of paracetamol (91).

4.4 Storage

Storability is an essential condition for the spreading of this technology into healthcare system, but until now only a few studies have been carried out on this subject. Storage studies are necessary for both raw materials (filaments) before printing, and for final products (printed tablets).

One of the tests required by the manufacturer of filaments is to test crystallisation versus time. Palekar *et al.* demonstrated that filaments made of PVA, sorbitol and baclofen, stored under 40°C and 75% RH during 90 days did not undergo any change and that baclofen remained in the crystalline state (57). Similar results were found for carvedilol 3D printed tablets which remained crystalline within several formulations after 1 month of storage in International Council of Harmonization (ICH) accelerated conditions (64).

For polymers with hygroscopic nature such as PVP, moisture uptake has been reported either in the filament or in the printed tablets. Moisture uptake can affect the mechanical properties of the filament and rendering it unfit for printing (97). For instance, after storage at 20°C over several weeks, deliquescence was noticed for filaments based on PVP especially those highly plastified (86). Moreover, molten flow rate during printing can be also modified due to the plasticizing effect of water lowering the glass transition temperature (78,96).

Besides mechanical and rheological alterations of the filaments, APIs in printed tablets can also be affected by humidity causing modifications on the final form morphology, changes on the release kinetics or even degradation.

In conclusion, both the filaments and prints can be altered during storage, and may require components to reduce humidity uptake or specific packaging (64).

4.5 How to improve printing quality

In Table 4 are described the most current problems encountered during printing in the reviewed FDM studies; Roots, effects on quality and potential solutions are also included.

PHENOMENON	DEFINITION / CAUSES	CONSEQUENCES ON PRODUCTION AND PRODUCT	POTENTIAL RECTIFICATIONS
Stringing / oozing	Common printing default leading to a not controlled flowing of the melt filament, through the nozzle; It results in the appearance of string within the printed part. Causes: lack of viscosity of the filament (« it is too runny ») in the nozzle	Low effect: can lightly alter the aimed dose in the pill	<ul style="list-style-type: none"> -Reduce the nozzle temperature (60) -Increase the retraction length -Increase the retraction speed -Optimize the movements of the nozzle
Delamination	Layers splitting by lack of adherence between each layer. Causes: -Filament temperature far below the glass transition temperature -Overplasticization of the filament (76)	Strong effect: can highly alter the release kinetic of active ingredient	<ul style="list-style-type: none"> -Increase the printing temperature, in order to promote adherence with the former layer -Increase the bed temperature: a long glass transition will promote the coalescence -Reduce fan speed (47) -Withdraw a plasticizer of the formulation (76) -Increase printing speed (47)
Warping	Bad adherence to the bed leading to partial or total detachment of the object during printing. Causes: -Shrinking of the first printed layer due to too fast cooling when material is deposited on the bed -Too small base surface	Serious effect: in case of unpasted of one unit, the entire batch could be disqualified	<ul style="list-style-type: none"> -Increase bed temperature -Use a blue painter's tape or a BuildTak® (56) or a printing extension as Stem, Brim or Raft to enlarge the contact area with the bed (37). However, the tray removal operation can spoil the printed drugs (97) and chemical interaction between polymer and blue tape have been reported yet (54) -Increase the contact area with bed by reorienting the object in the space (90) -Regulate the printing parameters of the first layer: increase it thickness, reduce printing and/or fan speed -Use a confined hood to control ambient temperature
Pill deformation by sagging	Object sagging during printing, due to a solidification deficiency. Causes: -Insufficient re-solidification time -Too high printing temperature -Overhang in the structure to be printed	Variable: can alter the kinetics	<ul style="list-style-type: none"> -Increase the nozzle speed fan (71) -Regulate ambient temperature (conditioned air) -Introduce compounds with high melting point in the filament (98)

Nozzle clogging	Nozzle clogging during printing; the causes are multiples: -Too high Temperature bringing on conglomerate of degradation particles (47) -Irregular distribution of particles within the filament and/or oversized solid conglomerate forming, exceeding the nozzle diameter (86) -Too high viscosity of the filament (64) -Filament breaking when passing through driving gears	Serious, the entire batch production can be interrupted	-Adjust and regulate the printing temperature -Use liquid lubricants with high boiling temperature as castor oil, oleic acid or peg 400. (58)
Rough Surface of the pill	Lose of smooth aspect of the pill, with cavity occurrence or aggregation on the surface. Cause : lack of flowability due to high filament viscosity (76)	Light effect: can weakly alter release kinetics because of the modification of contact area of the pill	-Reduce printing speed -Adjust extrusion multiplier -Input a plasticizer in the formulation (76) -Slow down print speed (47) -Slightly increase the nozzle temperature

Table 4. Current reported phenomem altering the printing quality and their impact on solid oral form batch production.

Some supplementary recommendations in order to get a controlled quality of printing are listed below:

- Limit over-extrusion or under-extrusion using a uniform filament both in diameter and composition (42,45).
- Carefully adjust the slicing parameters especially in case of risky steps (first layer, printing after a pause or overhang structure). For example, split the printing device in sections depending of the geometry to print and adapt each processing condition. For example, to facilitate adherence after filling step, the printing speed and the air flow rate can be reduced while increasing extrusion flow rate as if it was a new first layer (38,47).
- At the end of each deposited layer, little holes may form, even more importantly if the printing speed is too high and the layer height is low (46). Emerging weak zones can be prevented by avoiding the alignment of starting points at each layer configuring the start of the layer in different position from the previous one. (45).

4.6 Potential processing hazards

It is important to note that FDM technology is not always innocuous as Volatile Organic Compounds (VOCs) and micro-particles can be emitted by the printing process.

VOCs are produced by the partial degradation of the materials that constitute the filament (106). Degradation products depend on the thermal stability of the materials and the temperature reached during the extrusion process. For example, styrene is considered as potential carcinogenic by International Agency for Research on Cancer and its emission has been detected while printing with ABS filament (106).

Micro-particle emissions during printing are typically composed of Ultra Fine Particles (UFP), also called nanoparticles with diameter size <100 nm. Particle levels would depend on materials' nature and duration of the thermic treatment (107). It has been postulated that smaller are the particles, deeper they can invade the respiratory organ and cross physiological barriers (108). In short term, an asthma case (109), and bronchi irritations have been reported (110,111). Long term consequences of

repeated contact with UFP are not known yet, and none toxic limits have been so far settled by authorities (112).

Thus, it is recommended that the printing process should be performed in special correctly ventilated rooms or hoods, with filter media, and workers should wear individual protection devices.

To date the means of protection are in development; for example using partially open enclosures around the printer allowed to reduce the UFP level in the air up to 35% (113). Other emerging solutions are to pre-heat the platform and extruder before printing which reduces up to 75% of the UFP emission compared to conventional use of ABS filament (107) or to use photocatalytic filters to trap UFPs.

5 Use of printlets in the futur

Production rates of 3D printers are low, and FDM is not an exception. Unit production times by FDM are from 2 min (50) to 5 minutes for complex or bulky shaped final forms (77). Even if the parameters affecting the speed of production can be optimized and industrial printers composed of several nozzles can be envisaged, or combined with other technologies such as injection molding (81), obtaining production rates approaching those of direct compression tablet production (up to a million tablets/hour) is unlikely. Therefore, the future of FDM will not be replacing mass-production industry approaches, but rather be used as complementary technology. 3D printing cost efficiency has already been demonstrated for small-scale production. This feature combined with the high printing precision and the ability to limit wastage of API and excipients compared to conventional technologies may be of interest for orphan drug production (114). Moreover the rapid prototyping capability of FDM and its high adaptability can provide specific solutions for many personalization requiments in drug development research and precision medicine (28).

5.1 Dosages and kinetics achieved

For HME-FDM and Impregnation-FDM, the mass is directly correlated to the amount of active ingredient present in the printlet. Very good precision in the dosages is generally obtained with a typical mass standard deviation below 1% (99). Dosage obtained by Impregnation-FDM are low and ranged from 0.11 mg to 10 mg (31,33).

Still a therapeutic use for very low dosages molecules is possible. The high drug loading capability of HME-FDM makes possible to reach doses between 0.5 mg to 500 mg of API in the final print allowing more therapeutic options. HME-FDM is therefore compatible with the order of magnitude of most drugs and can already replicate doses of marketed drugs. This is for example the case of warfarin, a molecule with anticoagulant properties which therapeutic doses are between 0.5 and a few mg (102). The authors chose to load their filament at only 1%, in order to reach the targeted low doses while obtaining oral forms easy to handle. Another study highlighted the possibility of creating bilayer tablets with one of the layers printed with a filament lightly loaded with glimepiride (2%) and the other layer printed with a filament heavily loaded with metformin (50%) in order to successfully reproduce a widely sold anti-diabetic drug (Amaryl®) containing 500 mg of metformin and 2 mg of glimepiride (83). Improvements are still needed to obtain acceptable size tablets containing more than 500 mg of API.

In Print and fill, the amount of drug is directly correlated with the volume of API added during filling step. Current API ranges from 1.4 mg to 80 mg (35,37). Thus, Print and fill methodology can be adopted for the production of low-content drugs.

Release kinetics play a fundamental role alongside the dose in precision medicine. Indeed, the impact on the bioavailability for many active ingredients highly depends on whether the release takes place in the intestine or in the stomach. A good control of the release kinetics is essential in order to be able to treat pathologies, and to adapt treatments to specific phenomena altering intestinal transit i.e. gastroparesis, by-pass, or certain drugs such as tricyclic antidepressants.

A study realized in 2015 proposed a model for predicting the rate of dissolution of a printed tablet according to the initial surface area/volume ratio relationship (89) called specific area. This predicting model was completed by a 2018 study which showed how by controlling the surface area during dissolution process, a linear relationship between dissolution rate and surface area was yielded (63). The first conclusion is that release kinetics are directly related to the surface area evolution during dissolution; larger is the specific area faster is the dissolution. FDM-3D printing and its related materials favors obtaining extended release drugs profiles. Indeed, among the analyzed studies, 62.7% achieved a sustained release for their formulation. Various sustained release profiles have been reached varying from a few hundred

minutes to several days of release. Also, 13.3% studies obtained extended release behavior preceded by a lag time. Only 9.6% and 27.7% of studies obtained a delayed release and an immediate release behavior for their formulations, respectively. This is explained by the lack of polymers demonstrating a rapid disintegration in water. More in details, 75% of the studies having carried out a delayed release device used Print and Fill method. Impregnation-FDM technique showed sustained release profiles in 100% of the studies.

5.2 Strategy to modulate dosage and release kinetic

5.2.1 For HME-FDM and Impregnation-FDM

For these two approaches, dose and kinetic modulation could be achieved just before the printing start by varying: the printlet dimensions, the slicer parameters or the drug loading of the filament.

5.2.1.1 Modulation of the printlet dimensions

Changing the actual dimensions of a 3D printed object can modulate both the dose and the kinetics of the drugs.

The scaling factor is a slicer parameter which allows modulating the size of the object just before printing starts. Goyanes *et al.* used the scaling factor to adjust the total mass of tablets presenting different shapes (sphere, ring, cylindrical or caplets) (115). In a similar manner, Pietrzak *et al.* decided to vary the total volume of their printlet while keeping constant the ratio between each dimension. Expressing height and width as factors of length (“Length x Width x Height = $L \times L \times yL$ ” where x and y were constants), they were able to determine a cubic equation governing the relationship between dose of the active ingredient and volume of the tablet. Then, they demonstrated that the scaling factor was reliable in producing theophylline tablets at 5 different doses between 60 and 300 mg of active ingredient (50).

Another method consists in modifying a single dimension of the object. For example, Giamouxouzis *et al.* obtained a high correlation between theoretical volumes and drug content by setting as a constant the radius of a cylinder and only varying its height (83). A similar approach was employed by Tagami *et al.*, by fixing the height of a cylinder and adjusting its diameter (33). However it is known that dimension

modifications can also alter the drug release rate (57). Then, prior studies should define the range of dimensions in which the change in drug release rate is minimal and can be overlooked.

5.2.1.2 Modulation of the slicer' parameters

The shell thickness plays a big role on the release rate, with thicker shell delaying water permeation and therefore drug diffusion (76). Increasing the thickness of the shell can also reduce the global porosity of the object, thus slowing or delaying the kinetics of dissolution of the core. For example, an API-free shell has been used to obtain delayed release profiles hindering the penetration of the solvent inside the core of the device (63).

The infill is a parameter specific to 3D printing which allows modulating the quantity of material deposited inside the walls of the created object, at the core level. In current practice, a strong infill is used to consolidate an object. These physical properties are also found in the manufacturing of drugs by 3D, with an increase in the infill proportional to the force-to-break. However, the infill can also take on another interesting characteristic in the pharmaceutical field, by modifying the quantity of total raw material used to create a tablet, and therefore making possible to modulate the final dose.

For example, in a Goyanes' study, the infill parameter was used to modulate the dose of the yielded tablet. By varying the infill from 0 to 100% of 10 mm diameter and 3.6 mm high tablets, the total weight increased from 216.5 mg to 293.6 mg, representing an increase in total mass of around 36% (22).

However, the modulation of doses by the infill is more effective when the dimensions of the tablet are larger. Indeed, for small tablets, the shell occupies a preponderant volume on the core and varying the infill may not be an adequate solution to modulate the dose. This can have serious consequences, especially in pediatrics where it is necessary to adjust the doses, while keeping small sized tablets.

Besides its use to modulate the dose, the variation of the infill also plays a role in the dissolution kinetics of tablets. The polymer erosion can be increased while the specific surface area increases (and therefore while the infill increases), up to about 70% infill. Beyond this threshold, there is no longer an increase in the dissolution rate, and sometimes there is even a slowdown (29,84). This phenomenon is explained by

the decrease in the space accessible to the dissolution media and consequently by the decrease in exchanges between the interstices of the polymer and the solvent. The reduction of this exchange space can be potentiated by the following phenomena:

- Behavior of the polymer: if the polymer tends to swell in water, its dissolution can reduce the internal spaces (61).
- The flattening of the strands of filaments during extrusion. Instead of keeping a rectangular shape, some polymers take the form of a flattened cylinder blocking the internal pores (66).

In an interesting study, Novák *et al.* created a mathematical model that could predict the dissolution rate depending on the percentage of infill used. By crafting an original tablet design combining different infill regions in pie or stack structure, they could precisely predict and controlled the release kinetics of their device (66).

A study published by Tagami *et al.* showed that changing the flow rate could change the density of the tablet as an alternative to variation of the percentage of infill (33). The flow rate is a parameter of the slicer which governs the amount of filament pushed out of the nozzle per unit of time, by default it is set to 100%. Usually, it is used to compensate for changes in the diameter of the filaments. By setting a flow rate at 120%, Tagami highlighted that the density was increased by about 10% compared to a flow rate of 100%. Beyond 120%, the dimensions of the tablets and the quality of the printing were too irregular and could even lead to a decrease in density. The advantage of this strategy is that it changes the density homogeneously without distinction of the core and the shell of the tablet. Although this parameter ability to modify the final dose is low, it can be used in addition to the “infill parameter”. Impact on drug release rate was not explored in this study, however it can be expected the same results as modifying the infill density.

The infill pattern is usually known to influence the hardness of a printed object. It has been discovered that it can also play a role in the disintegration kinetics (61). Palekar and al explained it in their study in which the minicaplets with the “diamond-fast” infill pattern showed a significantly longer disintegration time compared to “sharkfill”, “linear” and “hexagonal” pattern due to internal geometry. On the contrary of these three last pattern, the “diamond-fast” pattern didn’t promote medium uptake and

busting from the center of the caplet, but rather external surface erosion (57). Then, the infill pattern could be chosen in order to slow down or accelerate the release.

5.2.1.3 Drug loading levels

When other strategy as modifying dimensions or slicing parameters could not permit to obtain the right dosage to comply with a medical prescription, using filaments with other drug loading levels could be an interesting alternative. Indeed, without changing any other parameters, changing concentration of active ingredient per gram of deposited filament induce the change of the total amount of drug in the final form. However, modifying the drug loading levels in the filament can also slightly alter the release kinetics of the obtained medicine, as higher drug loadings tend to accelerate the dissolution rate (76,91). This is explained by the fact that currently most of the polymers used have mechanisms of dissolution by erosion. An increase in the quantity of API implies a proportional reduction of the quantity of polymer leading to an acceleration of its erosion (62).

The necessity to get available filaments with different drug loading should be anticipated, especially for drugs with high therapeutic dose range.

5.2.2 For Print and fill approach

Unlike other techniques, *Print and fill* commonly uses a 0% infill in order to get the largest empty space possible which will be filled later with the API. In order to increase the internal space and thus the maximum API dosage, two strategies have been reported:

- Increasing the dimensions of the tablet (*via* the scaling factor, for example).
- Decreasing the shell thickness.

Actually, the thickness of the shell in the vertical axis is governed by the layer height in the slicer, which usually ranges from 0.1 to 0.4 mm but it can be adapted to lower values such as 0.05 mm (46). The lateral thickness is governed by the diameter of the printer tips ranging from 0.25 to 0.5 mm (41,55). In the absence of shrinking or sagging phenomenon, the side shell will be a multiple of the diameter of the tips. However, change in the release rate as to be expected as it has been demonstrated that thicker is the shell, slower is the API release phase (35,38,46). For example, in

the study performed by Maroni *et al.*, 1200 μm and 600 μm thick PVA shells showed a release delayed of 50 min and 15 min, respectively. Similar results were obtained with HPMC shells produced presenting 600 μm and 1200 μm thickness which showed a release lag-time increased twice from 55 to 110 min, respectively (37).

Caution should be taken as a too thin shell or the presence of porosity in the shell can promote an uncontrolled leakage of API and a premature release of the active ingredient (36,47). Thus, a smooth quality in shell printing is required to get reproducible experiments and results.

Four pore formation process have been identified as follow:

- **During the print and fill in “simultaneous” mode:** printing disrupts after each deposited layer, to let place to a micro-filling stage. When printing restarts for the next layer, the delay at printing resumption and the lack of adherence can promote pores in the new layer. Multiphase printing offers an overall better quality of shell printing, due to a unique single break (35).
- **With the type of shell pattern employed:** for instance, while a rectilinear pattern can lead to gaps of 100 μm , a concentric pattern can reach a more regular shell with better alignements between the strands (35).
- **According to the polymer nature:** a work comparing PLA and PVA found that while PLA yields a final volume of pores relatively low and interconnected, forming local long tubes between two strands, PVA had small and isolated pores with high total volume (45).
- **With the anisotropic properties of the printing process:** the layer in contact with the bed is usually of high quality and less porous than the lateral and bottom parts of the shell which need to be thicker or with supplementary layers to get similar release kinetics all around the printed parts (36).

5.3 New original properties through designs

The opportunity to manufacture medications with innovative shapes showing unique release rate behavior is one of the assets of FDM compared to traditional manufacturing. Some examples are given in Figure 7. These original designs can be classified as:

- **Accelerating release rate:** several studies used channels with different orientation and size into their tablets to increase the release rate. It has been

discovered that despite having a similar surface/volume ratio, caplets presenting short channels at the right angle to the long axis were more efficient to enhance dissolution than caplets with long channels parallel to the long axis (73). This is probably explained by the fact that water circulation is promoted in the case of short channels design. Another study produced tablets made of 9 connected blocks with 3 bridges, each block separated by gaps of various sizes. Smallest gaps (0.2 – 0.4 mm) swelled during dissolution and gave a gel which filled the gaps and reduced the dissolution rate randomly. Beyond 0.6 mm between gaps, the dissolution was predictable. With similar surface area/volume ratio, 85 to 90% of the API was released in 30 min with gaps between 1 to 1.2 mm, while only less than 40% release was observed in the same time for tablets presenting no gaps (101). Similar results have been identified with the production of radiator-like tablets, in which a minimal 0.5 mm space between plates was necessary to enhance dissolution rate (100).

- **Slowing down the release:** a donut shaped pill has been printed with upper and bottom part composed of API-free PLA shell, not soluble in water. The inner body was composed of PVA and hydrochlorothiazide. In order to reinforce the structure and to avoid a rapid PVA splitting, an internal ring of PLA was also added. This structure allowed to keep the specific surface constant along dissolution in the media and a zero order kinetics was obtained during 240 min (75). Another study produced duotablets with 2 different concentrations of the same drug in the inner and the outer layer. This structure allowed sustained release kinetics of 5 hours, thanks to the concentration gradients opposed to the decreasing area/volume ratio (71).
- **Delaying the release:** Goyanes *et al.* developed 2 types of devices. a multilayer caplet with 2 API, each API was deposited alternately from one layer to another. And a device combining an outer compartment composed of an API and an inner compartment with a second API. The first device led to a similar dissolution for both APIs. The second one showed a lag-time for the API in the inner compartment. In this case, outer part played the role of a shell. Thicker it is, higher is the lag-time to allow the water reaches the inner compartment (62).

- **Gastroretentive devices:** two type of gastroretentive solid oral form have been realized that can be distinguished by the way they are able to stay in the stomach: floating devices and spatial encumbrance devices. Three studies produced hollow floating tablets by HME-FDM showing buoyant ability from 9h to 24h (67,79,93). Similar buoyant properties was obtained by producing hollow windowed devices filled with a tablet by Print and fill technique with buoyant property from 24h to more than 72h (43,48). A recent work produced devices which aim to resist gastric emptying by spatial encumbrance: a cylindrical helix shaped tablet has been prototyped by FDM, and supercoiled to fit a capsule for administration. Once released in the stomach, these devices shifted to a bulky shape showing sustain release from 2 to 5h depending of the absence or the presence of coating (55).
- **Other:** an interesting trial also reported the manufacture of printed drugs with the shape of an egg showing deterrent misuse properties and preventing snorting or crushing opioid drugs (82)

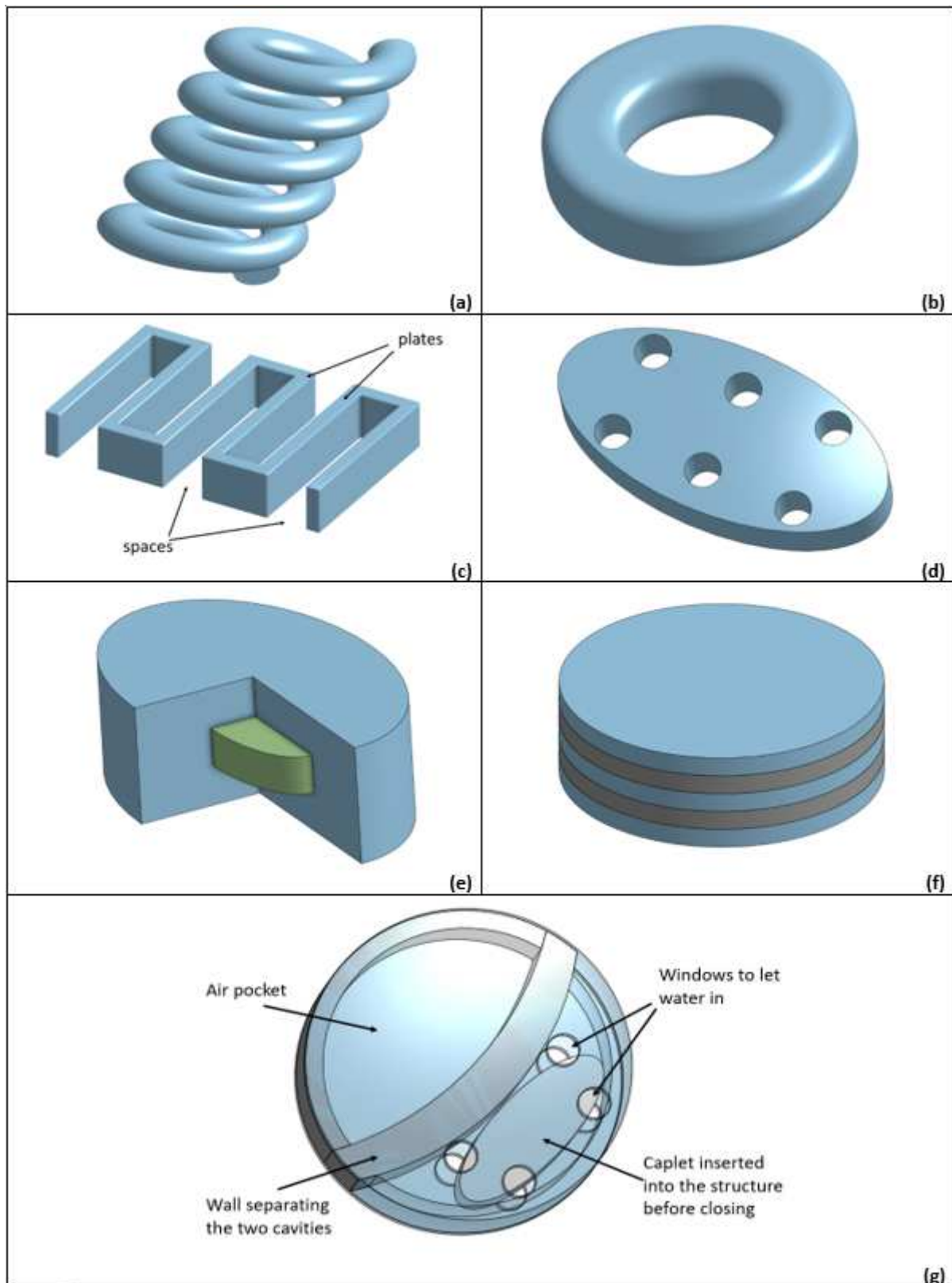

Figure 7. New shapes of drugs reported. (a) Helix-shaped drug, (b) donut-shaped drug, (c) radiator like design with space between plates to facilitate contact with water, (d) perforated caplet to facilitate contact with water, (e) two API combination: the first is located in the external part (in blue) and the second in the internal part (in green), (f) combination of two API which are in alternating layers (black and blue), (g) 3D printed gastroretentive drug with buoyant properties.

5.4 Expected benefits from using FDM to print drugs

5.4.1 Drug development research

Research is the first sector that could benefit from FDM-3D printing, since it could find a special place for the development of drugs, from the early stages to clinical trials in humans. Indeed, its adaptability and ease to change printing parameters between each print greatly facilitates the design stages, and makes possible to test different bearings in record time compared to conventional tablets manufacturing processes (37).

FDM *In-vivo* research involving animals such as beagle dogs (38,43), Sprague dawley rats (39,102) and New Zealand rabbits (48,67) is already underway. *In-vivo* testing, using *Print and fill* FDM technique can be generalized to several API and adapted to animals by generating different printing sizes (39). Also, it is possible to evaluate the drug behavior in the different compartments of the digestive tract of the animal without using invasive methods just by delaying the release through a variation of the shell thickness. This technique can offer a real boost for research and could be an important source of savings by reducing formulation time and also reducing raw materials waste (38,45).

Finally, for active ingredients with solubility issues, the HME-FDM technique represents a possible new galenical alternative due to its ability to promote the formation of API amorphous form enhancing its solubility.

5.4.2 Precision medicine

Another field in which FDM technique can bring benefits is in precision medicine. Till today, adjusting a right dose to a patient, is often done using liquids forms (injectable or drinkable), and very rarely oral solid forms are employed. However, liquid forms have the inconvenient to be less stable, need to include complementary materials (syringes and dosing pipettes) and a nursing act for administration is sometimes required.

Moreover, liquid dosage forms are prone to manipulation and dosing errors (77). Thus, FDM technique could afford solutions to patients with tailored oral solid forms, more secure and easier to use. It also could allow the development of new

formulations for some treatments in oral forms in which syrups can not be administrated (for instance API sensitive to gastric acid). Pediatrics and geriatrics are known to regularly require case by case therapeutics to fit their specific needs. Therefore, these populations are good candidates to tailored treatments.

5.4.2.1 Pediatric

Pediatric drugs strongly lack of galenic forms for babies and young children (116), with up to 40% of all pediatric prescriptions needed to be compounded in the USA (117). FDM technology can be considered as a potential alternative or a complementary strategy to compounding activity. Indeed, it could help automating a part of this activity and then to secure it.

- Pediatric doses adaptation

From neonatology to adolescence, children cross various physiological states which require an adjustment of the therapeutic forms and doses (77).

The titration of active compound is often related to the age, the weight and/or the surface area. For most compounded drugs in France (such as amiodarone, captopril, spironolactone, esomeprazole and caffeine) doses vary from some to hundreds milligrams which perfectly fit doses reached by FDM technology.

- Pediatric galenic forms and tolerance

Oral forms must offer a presentation that suits the age of patients. According to the EMA, before the age of 1 month, the oral form has to be in a liquid phase in order to be mixed with baby food or to be directly drunk. Between 1 month and 2 years old, orodispersible forms become acceptable. Then, after 2 years old, the use of tablets becomes one of the possibilities (118). Although effervescent or dispersible forms have not been yet reached by FDM, this technology is still a suitable technique for preparation of tablets for children from 2 years old. It could become a standard allowing to adapt the dose and the size of the tablets to each patient. However, although the polymers used to date are considered generally recognized as safe in adults, the nature and dose tolerated in children may be different and must be ensure. Thus, pediatric tolerance studies and development of new polymeric excipients will go hand in hand with the opening of FDM to pediatrics.

- Observance

The development of a new pediatric drug produced by FDM technology must be associated with a particular care of the taste and palatability, because it is a key factor for acceptance by young children.

In order to improve the observance by children, a study produced children-attractive chewable tablets of indomethacin, looking like candies of various forms and sizes. The results proved excellent taste masking properties while maintaining similar release kinetics among the various forms (77).

5.4.2.2 Geriatric

Geriatric is another care sector which could take advantage of FDM technique. In general, elderly population is more prone to present alteration of organs involved in the clearance of chemical treatments (as kidneys) and a high sensibility to some compounds such as psychotropic and atropinic agents. Therefore, it is often necessary to adapt medications to lower levels doses. Furthermore, elderly patients can be in state of heavy treatment with numerous medicines to take every day (sometimes more than 10 drugs). With such complex health management, defective observance is often reported. So, FDM combines several reasons to be benefic to this population:

Firstly, most of the printed drugs present sustained release kinetics as previously mentioned. This kinetic is generally associated to less frequent side effects (119). Secondly, it reduces drug administration frequencies as showed by Chai et al. This study demonstrated that a floating device remaining in the stomach showed domperidone extended release, allowing a higher bio-availability and steady-state of domperidone concentration in the plasma (67). Finally, it is possible to combine two or more APIs in a therapeutic unit. Indeed, the association of two APIs with different release kinetics has been realized in several studies: For example, the association of glimepiride for immediate delivery and metformin for sustain release has been realized by HME-FDM (83). By Print and fill method, similar results aiming differentiated kinetics have been reached, by using two compartments with active compounds separated with an internal joint (37). And the association of physical or

chemically incompatible API has been also possible by using these compartments (62). To date, up to 4 APIs have been combined in a single FDM tablet (80).

5.4.3 Toward on demand medicine?

The use of FDM technology represents a new step into the production of tailored medicine as it is able to precisely control at the same time the dose, kinetics, form, taste and color of a drug. Moreover, in modern medicine the patient is at the center of the medical decision and his opinion counts.

In our opinion, as a form could have an impact on the drug release, any change must be anticipated, for example, by providing a list of available forms whose prior studies will ensure bioequivalence. Furthermore, the placebo or nocebo effect of shape, taste and color features must not be overlooked and should be studied before offering choice to the patient. Whatever the results of these studies, we believe that the final decision on any organoleptic change of a drug should be a medical decision after a case-by-case evaluation of the patient's request.

5.5 Place of FDM in the healthcare system

The place of FDM in the healthcare sector is not stated yet and many scenarios have been developed by Lind *et al.* (10), as the printing equipment will be placed either in the user's home, in pharmacies or in the pharmaceutical industry.

From our point of view, at present, pharmaceutical industries have centralized production units. The same scenario is hardly compatible with FDM as the distribution of a personalized batch to each patient could be an issue. We believe that in order to be integrated into precision medicine, printers must offer an effective territorial network. The city drugstores and/or the hospitals, due to their distribution on the territory can therefore represent a leading solution and has in addition the following advantages:

- Compounding pharmacies already have the infrastructure to accommodate this technology and the analytical tools to ensure batch controls (26).
- Legislative: the preparation of offlabel medicines is allowed in pharmacies that have authorization. In these places, pharmacists, with adequate courses

during their study, will be able to ensure control and pharmaceutical release of manufactured 3D printed drugs.

- It is usual to pick up medications from the pharmacy, which would not change habits for patients nor change the usual drug delivery circuit (10).
- The pharmacy can monitor treatment deliveries;
- Qualified pharmaceutical staff can answer patients' questions about their treatment and give advice during dispensing of the drug.

More placing production and delivery at the same place will reduce the need of distribution system and can contribute to fight against counterfeiting. FDM could also help limiting shortages, especially for patients without alternative treatment strategy (119).

6 The challenges of FDM 3D printing

Implementation of FDM for tailored medicines faces several challenges notably for regulatory agencies. Despite of the high interest of the FDM process in the medical field, no GMP for FDM printer or softwares, are yet available (26). Neither GMP are available for input materials as pharmaceutical filaments. Pharmacopoeias do not contain methods of analysis for tablets produced by FDM, and the existing methods for the other galenical forms are difficult to apply. More, in the case of production of a printed drug for a patient, the regulatory status of the final products remains unknown (120), as does who will be responsible for any defective product or the appearance of an adverse effect on the patient (23). And other issues as patent regulations for designing new 3D printed drug in response to medical prescription can be raised. The involvement of health authorities is now an essential step to the approval of this technology and its widespread use (119). From our point of view, to gain acceptance of FDM 3d printing for oral forms drugs, first of all manufacturing process aspects have to be known and be under control, from design to final product.

6.1 Control variability on computer aided design, slicers and printers

The design is drawn on a Computer Aided Design (CAD) software and is conventionally saved in a stl. file (as stereolithography file), the format most widely used in 3D printing. Then, another software called “slicer” transforms in several seconds the digital design (from the stl. file) into a sequence of instructions to be carried out by the printer, generating a Gcode file. These instructions include for

example the working temperatures of the bed and the extruder, the displacements of the printing head, the quantities of filament to be extruded over time, etc... Once this Gcode is loaded into the printer, the printing can start.

Depending on the complexity of the shape to be produced, designing on CAD software can take few seconds (for simple geometries such as a cylinder or a sphere) and a few hours for complex models. There is a broad variety of CAD softwares available in the market. In the studies reviewed fifteen different softwares were used. Despite 10% missing data due to articles' lack of information two of the most used softwares are commercialized by Autodesk®: AutoCAD ® (used by 23% of the studies) and 3DS MAX Design® (used by 19% of the studies).

Stereolithography files (stl.) were used to save the design drawn from the CAD software in all studies mentioning the files format (90%). Based on a triangular geometry, it retains the external surface of the drawing by transforming it into a sum of small triangles in space. From our point of view, the diversity of CADs used is not a source of variability for the final product. The lack in variability comes from the use of common mathematical functions that for simple forms such as conventional medicines do not differ one from the other. Moreover, all designs are registered in the same *stl.* format.

In our opinion, slicers represent a source of variability on the final object based on their different configurable settings and their own algorithms to adjust printing. In our study, we denombrated 9 different softwares used to produce oral medicines. Makerware associated by default with Makerbot Replicator printer is the most used, before Cura.

More variations are caused by the large variety of printers existing nowadays, with none GMP associated, making uneasy the comparison between studies. Among the 72 analyzed articles, 23 different brands of printers have been identified. And between them, "MakerBot Replicator 2" and "2x" are the more used printers to produce solid oral forms (37.5% of the studies).

Several elements can change between printers, such as the drive mode of the filament (direct extrusion or bowden), the filament feeder, the heating head (composed of the liquefier and the nozzle) and the plate. All may have an importance on the success and the quality of the printed drug:

- **The drive mode** of the filament is governed by the position of the filament feeder in the printer. In direct extrusion, filament feeder is above the liquefier within the extruder head. Whereas in bowden extrusion printers the filament feeder is placed in the back of the printer. The aim of bowden extruders is to alleviate the extruder head in order to print more accurately and quickly. Filaments using this motion system are more flexible because they undergo important flexing forces compared to direct extrusion printers. On this point, Fuenmayor *et al.* advised other researchers to rather use direct drive extruder in order that more filaments are compatible with FDM (60).
- **The filament feeder** is also responsible of accepted filament diameter (usually either 1.75 or 2.85 mm) and its tolerance (on average of 0.15 mm). This is a critical area for the filament because they must not break when passing through the drive gears. Traction and compressive forces exerted by the two gear wheels are variable from one printer to another, which explain why Melocchi *et al.* changed their springs with one of lower stiffness in extrusion head to broaden its use to more filaments (70).
- **The nozzle** is often screwed on the heating head and can be removed easily for cleaning purposes. The nozzle diameter ranging from 0.25 to 0.5 mm (41,55), usually made of nylon, defines the width of the strands deposited during extrusion.
- The absence of **automated leveling plate** has also been identified as a source of variability in several studies by changing the thickness of the first layer.
- The lack of **heating bed** in some printers can favour undesirable warping events.

According to these variables, studies are currently lacking of standardized results. Optimization of future machines and their associated software is needed to increase the level of quality and reproducibility.

6.2 Quality by design

The ICH, FDA and EMA are recommending to manufacturers the use of a QbD approach in the development of new pharmaceutical forms in order to contribute to a good level of quality, safety and efficacy of the final product (121,122). This modern approach of pharmaceutical quality consists in “design a quality product and its

manufacturing process to consistently deliver the intended performance of the product” (123). QbD approach can be sum up in several steps in the following order:

- to specify the **Quality Target Product Profile**. Typically, this includes: drug, indication, route of administration, dosage, appearance of the final product and packaging.
- to deduce the **Critical Quality Attributes** (124). These CQAs are critical control elements to ensure quality of final products with the performance requirements (physical, chemical, biological property, etc.) (125).
- to identify and control the source of variability, as **Critical Material Attributes** or **Critical Process Parameters** by promoting tools such as experience plans or multiple regression analysis.
- to define a **Design Space** and its control strategy to make the link between the knowledge acquired on the input variables and the product expected output quality. ICH recommends using controls throughout the production process to reduce end-of-process testing (123).
- to anchor the process in a life cycle management and continuous improvement.

Once validated by the authorities, QbD ensures greater flexibility and post-approval changes within the design space will be simplified (125).

3D printing of medication may be subject to the QbD approach especially for several reasons including:

- to help control source of variability and the risk assessment in the FDM technique.
- medicine customization could be included in the design space.
- to facilitate implementation of FDM-3D printing in pharmacy by using Process Analytical Technology and so reducing the number of expensive end-of-process destructive tests.
- to help the acceptance of this new technology by the health authorities like EMA or FDA.

For instance, from the hot melt extruder stage to the printer, knowing the mean residence time of the particles and controlling the temperatures involved by in-line sensors would guarantee the purity of the final product and the non-appearance of

thermal degradation products during the process. On other hand, one of the most important CMA influencing the mechanical resilience, the dimensionnal and dosing accuracy is the regularity of the filament diameter (77,91,99). It is therefore recommended to systematically control filament diameter and any variation beyond the acceptable range should lead to the filament quarantine or destruction. A trial also identified that the weight of the printed object could vary depending of the printing speed; higher speeds resulting in lighter printed objects (54). Printing speed limit should be identified to maintain quality and reproducibility.

For a tablet-shaped object, some characteristics like hardness do not need to be included in the control strategy since the materials involved and the resulting printed tablets often exceed the operating limits of hardness testers (far above 200-300 Newton) (62,75). Similarly, the tablets produced by FDM are typically not affected by friability issues. With the exception of one study in which was found a friability of 0.55% (85), all the other studies showed friability of 0%. This absence of friability can be highlighted as one of the greatest advantages of FDM compared to other 3D printing processes.

7 Conclusion

In this review main features and conclusions of 72 studies and trials have been compared, discussed and analysed. This thorough comparison allowed to point out the conditions of good manufacturing and potential benefits of 3D printing for drug dry oral forms. After six years of increasing studies on drug production by 3D printing, technical parameters such as excipients, time, temperature, shape, action kinetics etc. are now well known and more and more controlled, including their variability.

In order to ensure quality standards of materials products, processes and environment, which satisfy manufacturers, researchers and patients, this emerging process still needs to develop and provide procedures like GMP and QbD.

Due to its efficiency, versatily and easy modulation of the dose, 3D Printing and overall HME-FDM process, seem a very promising technique to produce oral drug forms for precision medicine, specially for populations like children, elderly and orphan treatments.

Furthermore, preliminary studies have proven FDM-HME technique interesting for *in vivo* research due to its adaptation to short runs and flexibility. It can be therefore expected that these studies could be promptly extended to clinical assays on human.

8 Fundings

This research did not receive any specific grant from funding agencies in the public, commercial, or not-for-profit sectors.

9 References

1. Özdemir V, Dove ES, Gürsoy UK, Şardaş S, Yıldırım A, Yılmaz ŞG, et al. Personalized medicine beyond genomics: alternative futures in big data-proteomics, enviroptome and the social proteome. *J Neural Transm (Vienna)*. 2017;124(1):25–32.
2. Vicini P, Fields O, Lai E, Litwack ED, Martin A-M, Morgan TM, et al. Precision medicine in the age of big data: The present and future role of large-scale unbiased sequencing in drug discovery and development. *Clin Pharmacol Ther*. 2016 Feb;99(2):198–207.
3. Vaithinathan AG, Asokan V. Public health and precision medicine share a goal. *J Evid Based Med*. 2017 May;10(2):76–80.
4. Research C for DE and. Science & Research (Drugs) - Table of Pharmacogenomic Biomarkers in Drug Labeling [Internet]. [cited 2019 Mar 29]. Available from: <https://www.fda.gov/Drugs/ScienceResearch/ucm572698.htm>
5. ClinVar - ClinGen | Clinical Genome Resource [Internet]. [cited 2019 Mar 29]. Available from: <https://www.clinicalgenome.org/data-sharing/clinvar/>
6. Darwich AS, Ogungbenro K, Vinks AA, Powell JR, Reny J-L, Marsousi N, et al. Why has model-informed precision dosing not yet become common clinical reality? lessons from the past and a roadmap for the future. *Clin Pharmacol Ther*. 2017 May;101(5):646–56.
7. Mould DR, D'Haens G, Upton RN. Clinical Decision Support Tools: The Evolution of a Revolution. *Clin Pharmacol Ther*. 2016 Apr;99(4):405–18.
8. Flint RB, Weteringen W van, Voller S, Poppe JA, Koch BCP, de Groot R, et al. Big Data Analyses for Continuous Evaluation of Pharmacotherapy: A Proof of Principle with Doxapram in Preterm Infants. *Curr Pharm Des*. 2017;23(38):5919–27.

9. Alomari M, Mohamed FH, Basit AW, Gaisford S. Personalised dosing: Printing a dose of one's own medicine. *International Journal of Pharmaceutics*. 2015 Oct 30;494(2):568–77.
10. Lind J, Källemark Sporrang S, Kaae S, Rantanen J, Genina N. Social aspects in additive manufacturing of pharmaceutical products. *Expert Opinion on Drug Delivery*. 2017 Aug 3;14(8):927–36.
11. Howard M, Barber J, Alizai N, Rostami-Hodjegan A. Dose adjustment in orphan disease populations: the quest to fulfill the requirements of physiologically based pharmacokinetics. *Expert Opin Drug Metab Toxicol*. 2018 Dec;14(12):1315–30.
12. Pea F. Pharmacokinetics and drug metabolism of antibiotics in the elderly. *Expert Opin Drug Metab Toxicol*. 2018 Oct;14(10):1087–100.
13. McCune JS, Batchelder A, Guthrie KA, Witherspoon R, Appelbaum FR, Phillips B, et al. Personalized dosing of cyclophosphamide in the total body irradiation-cyclophosphamide conditioning regimen: a phase II trial in patients with hematologic malignancy. *Clin Pharmacol Ther*. 2009 Jun;85(6):615–22.
14. Alhnan MA, Okwuosa TC, Sadia M, Wan K-W, Ahmed W, Arafat B. Emergence of 3D Printed Dosage Forms: Opportunities and Challenges. *Pharmaceutical Research*. 2016 Aug;33(8):1817–32.
15. Younis IR, Robert Powell J, Rostami-Hodjegan A, Corrigan B, Stockbridge N, Sinha V, et al. Utility of Model-Based Approaches for Informing Dosing Recommendations in Specific Populations: Report From the Public AAPS Workshop. *J Clin Pharmacol*. 2017;57(1):105–9.
16. Neely M, Jelliffe R. Practical therapeutic drug management in HIV-infected patients: use of population pharmacokinetic models supplemented by individualized Bayesian dose optimization. *J Clin Pharmacol*. 2008 Sep;48(9):1081–91.

17. Saltz BL, Woerner MG, Robinson DG, Kane JM. Side effects of antipsychotic drugs. Avoiding and minimizing their impact in elderly patients. *Postgrad Med.* 2000 Feb;107(2):169–72, 175–8.
18. Chan IS, Ginsburg GS. Personalized medicine: progress and promise. *Annu Rev Genomics Hum Genet.* 2011;12:217–44.
19. Perera V, Gross AS, Polasek TM, Qin Y, Rao G, Forrest A, et al. Considering CYP1A2 phenotype and genotype for optimizing the dose of olanzapine in the management of schizophrenia. *Expert Opin Drug Metab Toxicol.* 2013 Sep;9(9):1115–37.
20. WarfarinDosing [Internet]. [cited 2020 Apr 28]. Available from: <http://www.warfarindosing.org/Source/Home.aspx>
21. Pravin S, Sudhir A. Integration of 3D printing with dosage forms: A new perspective for modern healthcare. *Biomed Pharmacother.* 2018 Nov;107:146–54.
22. Goyanes A, Buanz ABM, Basit AW, Gaisford S. Fused-filament 3D printing (3DP) for fabrication of tablets. *International Journal of Pharmaceutics.* 2014 Dec;476(1–2):88–92.
23. Gioumouxouzis CI, Karavasili C, Fatouros DG. Recent advances in pharmaceutical dosage forms and devices using additive manufacturing technologies. *Drug Discovery Today.* 2019 Feb 1;24(2):636–43.
24. Norman J, Madurawe RD, Moore CMV, Khan MA, Khairuzzaman A. A new chapter in pharmaceutical manufacturing: 3D-printed drug products. *Advanced Drug Delivery Reviews.* 2017 Jan;108:39–50.
25. Vithani K, Goyanes A, Jannin V, Basit AW, Gaisford S, Boyd BJ. An Overview of 3D Printing Technologies for Soft Materials and Potential Opportunities for Lipid-based Drug Delivery Systems. *Pharm Res.* 2018 Nov 7;36(1):4.

26. Araújo MRP, Sa-Barreto LL, Gratieri T, Gelfuso GM, Cunha-Filho M. The Digital Pharmacies Era: How 3D Printing Technology Using Fused Deposition Modeling Can Become a Reality. *Pharmaceutics*. 2019 Mar 19;11(3).
27. Awad A, Trenfield SJ, Gaisford S, Basit AW. 3D printed medicines: A new branch of digital healthcare. *International Journal of Pharmaceutics*. 2018 Sep 5;548(1):586–96.
28. Trenfield SJ, Awad A, Goyanes A, Gaisford S, Basit AW. 3D Printing Pharmaceuticals: Drug Development to Frontline Care. *Trends in Pharmacological Sciences*. 2018 May 1;39(5):440–51.
29. Goyanes A, Buanz ABM, Hatton GB, Gaisford S, Basit AW. 3D printing of modified-release aminosalicilate (4-ASA and 5-ASA) tablets. *European Journal of Pharmaceutics and Biopharmaceutics*. 2015;89:157–62.
30. Ibrahim M, Barnes M, McMillin R, Cook DW, Smith S, Halquist M, et al. 3D Printing of Metformin HCl PVA Tablets by Fused Deposition Modeling: Drug Loading, Tablet Design, and Dissolution Studies. *AAPS PharmSciTech*. 2019 Jul;20(5):195.
31. Skowrya J, Pietrzak K, Alhnan MA. Fabrication of extended-release patient-tailored prednisolone tablets via fused deposition modelling (FDM) 3D printing. *European Journal of Pharmaceutical Sciences*. 2015;68:11–7.
32. Beck RCR, Chaves PS, Goyanes A, Vukosavljevic B, Buanz A, Windbergs M, et al. 3D printed tablets loaded with polymeric nanocapsules: An innovative approach to produce customized drug delivery systems. *International Journal of Pharmaceutics*. 2017 Aug 7;528(1):268–79.
33. Tagami T, Fukushige K, Ogawa E, Hayashi N, Ozeki T. 3D Printing Factors Important for the Fabrication of Polyvinylalcohol Filament-Based Tablets. *Biol Pharm Bull*. 2017;40(3):357–64.
34. Goyanes A, Buanz ABM, Basit AW, Gaisford S. Fused-filament 3D printing (3DP) for fabrication of tablets. *International Journal of Pharmaceutics*. 2014;476(1–2):88–92.

35. Okwuosa TC, Soares C, Gollwitzer V, Habashy R, Timmins P, Alhnan MA. On demand manufacturing of patient-specific liquid capsules via co-ordinated 3D printing and liquid dispensing. *European Journal of Pharmaceutical Sciences*. 2018;118:134–43.
36. Linares V, Casas M, Caraballo I. Printfills: 3D printed systems combining Fused Deposition Modeling and Injection Volume Filling. Application to colon-specific drug delivery. *Eur J Pharm Biopharm*. 2018 Nov 23;
37. Maroni A, Melocchi A, Parietti F, Foppoli A, Zema L, Gazzaniga A. 3D printed multi-compartment capsular devices for two-pulse oral drug delivery. *Journal of Controlled Release*. 2017 Dec 28;268:10–8.
38. Smith D, Kapoor Y, Hermans A, Nofsinger R, Kesisoglou F, Gustafson TP, et al. 3D printed capsules for quantitative regional absorption studies in the GI tract. *Int J Pharm*. 2018 Oct 25;550(1–2):418–28.
39. Goyanes A, Fernández-Ferreiro A, Majeed A, Gomez-Lado N, Awad A, Luaces-Rodríguez A, et al. PET/CT imaging of 3D printed devices in the gastrointestinal tract of rodents. *International Journal of Pharmaceutics*. 2018;536(1):158–64.
40. Gioumouxouzis CI, Chatzitaki A-T, Karavasili C, Katsamenis OL, Tzetzis D, Mystiridou E, et al. Controlled Release of 5-Fluorouracil from Alginate Beads Encapsulated in 3D Printed pH-Responsive Solid Dosage Forms. *AAPS PharmSciTech*. 2018 Nov;19(8):3362–75.
41. Krause J, Bogdahn M, Schneider F, Koziolk M, Weitschies W. Design and characterization of a novel 3D printed pressure-controlled drug delivery system. *European Journal of Pharmaceutical Sciences*. 2019;140:105060.
42. Melocchi A, Parietti F, Loreti G, Maroni A, Gazzaniga A, Zema L. 3D printing by fused deposition modeling (FDM) of a swellable/erodible capsular device for oral pulsatile release of drugs. *Journal of Drug Delivery Science and Technology*. 2015 Dec 1;30:360–7.

43. Shin S, Kim TH, Jeong SW, Chung SE, Lee DY, Kim D-H, et al. Development of a gastroretentive delivery system for acyclovir by 3D printing technology and its in vivo pharmacokinetic evaluation in Beagle dogs. Uzun E, editor. PLoS ONE. 2019 May 15;14(5):e0216875.
44. Xu X, Zhao J, Wang M, Wang L, Yang J. 3D Printed Polyvinyl Alcohol Tablets with Multiple Release Profiles. Sci Rep. 2019 Dec;9(1):12487.
45. Markl D, Zeitler JA, Rasch C, Michaelsen MH, Müllertz A, Rantanen J, et al. Analysis of 3D Prints by X-ray Computed Microtomography and Terahertz Pulsed Imaging. Pharm Res. 2017 May 1;34(5):1037–52.
46. Matijašić G, Gretić M, Vinčić J, Poropat A, Cuculić L, Rahelić T. Design and 3D printing of multi-compartmental PVA capsules for drug delivery. Journal of Drug Delivery Science and Technology. 2019;52:677–86.
47. Smith DM, Kapoor Y, Klinzing GR, Procopio AT. Pharmaceutical 3D printing: Design and qualification of a single step print and fill capsule. International Journal of Pharmaceutics. 2018;544(1):21–30.
48. Fu J, Yin H, Yu X, Xie C, Jiang H, Jin Y, et al. Combination of 3D printing technologies and compressed tablets for preparation of riboflavin floating tablet-in-device (TiD) systems. International Journal of Pharmaceutics. 2018;549(1):370–9.
49. Nober C, Manini G, Carlier E, Raquez J-M, Benali S, Dubois P, et al. Feasibility study into the potential use of fused-deposition modeling to manufacture 3D-printed enteric capsules in compounding pharmacies. International Journal of Pharmaceutics. 2019;569:118581.
50. Pietrzak K, Isreb A, Alhnan MA. A flexible-dose dispenser for immediate and extended release 3D printed tablets. European Journal of Pharmaceutics and Biopharmaceutics. 2015;96:380–7.
51. Thiry J, Krier F, Evrard B. A review of pharmaceutical extrusion: critical process parameters and scaling-up. Int J Pharm. 2015 Feb 1;479(1):227–40.

52. Tan DK, Maniruzzaman M, Nokhodchi A. Advanced Pharmaceutical Applications of Hot-Melt Extrusion Coupled with Fused Deposition Modelling (FDM) 3D Printing for Personalised Drug Delivery. *Pharmaceutics*. 2018 Oct 24;10(4).
53. Zhang J, Feng X, Patil H, Tiwari RV, Repka MA. Coupling 3D printing with hot-melt extrusion to produce controlled-release tablets. *International Journal of Pharmaceutics*. 2017;519(1–2):186–97.
54. Alhijaj M, Nasereddin J, Belton P, Qi S. Impact of Processing Parameters on the Quality of Pharmaceutical Solid Dosage Forms Produced by Fused Deposition Modeling (FDM). *Pharmaceutics*. 2019 Nov 27;11(12):633.
55. Melocchi A, Uboldi M, Inverardi N, Briatico-Vangosa F, Baldi F, Pandini S, et al. Expandable drug delivery system for gastric retention based on shape memory polymers: Development via 4D printing and extrusion. *International Journal of Pharmaceutics*. 2019;571:118700.
56. Jamróz W, Kurek M, Łyszczarz E, Szafranec J, Knapik-Kowalczyk J, Syrek K, et al. 3D printed orodispersible films with Aripiprazole. *International Journal of Pharmaceutics*. 2017;533(2):413–20.
57. Palekar S, Nukala PK, Mishra SM, Kipping T, Patel K. Application of 3D printing technology and quality by design approach for development of age-appropriate pediatric formulation of baclofen. *International Journal of Pharmaceutics* [Internet]. 2018; Available from: <http://www.sciencedirect.com/science/article/pii/S0378517318308883>
58. Okwuosa TC, Pereira BC, Arafat B, Cieszyńska M, Isreb A, Alhnan MA. Fabricating a Shell-Core Delayed Release Tablet Using Dual FDM 3D Printing for Patient-Centred Therapy. *Pharm Res*. 2017;34(2):427–37.
59. Goyanes A, Chang H, Sedough D, Hatton GB, Wang J, Buanz A, et al. Fabrication of controlled-release budesonide tablets via desktop (FDM) 3D printing. *International Journal of Pharmaceutics*. 2015;496(2):414–20.

60. Fuenmayor E, Forde M, Healy AV, Devine DM, Lyons JG, McConville C, et al. Material Considerations for Fused-Filament Fabrication of Solid Dosage Forms. *Pharmaceutics*. 2018 Apr 2;10(2).
61. Fuenmayor E, Forde M, Healy AV, Devine DM, Lyons JG, McConville C, et al. Comparison of fused-filament fabrication to direct compression and injection molding in the manufacture of oral tablets. *International Journal of Pharmaceutics*. 2019;558:328–40.
62. Goyanes A, Wang J, Buanz A, Martínez-Pacheco R, Telford R, Gaisford S, et al. 3D Printing of Medicines: Engineering Novel Oral Devices with Unique Design and Drug Release Characteristics. *Molecular Pharmaceutics*. 2015 Nov 2;12(11):4077–84.
63. Tagami T, Nagata N, Hayashi N, Ogawa E, Fukushige K, Sakai N, et al. Defined drug release from 3D-printed composite tablets consisting of drug-loaded polyvinylalcohol and a water-soluble or water-insoluble polymer filler. *International Journal of Pharmaceutics*. 2018;543(1):361–7.
64. Ilyés K, Kovács NK, Balogh A, Borbás E, Farkas B, Casian T, et al. The applicability of pharmaceutical polymeric blends for the fused deposition modelling (FDM) 3D technique: Material considerations–printability–process modulation, with consecutive effects on in vitro release, stability and degradation. *European Journal of Pharmaceutical Sciences*. 2019;129:110–23.
65. Saviano M, Aquino RP, Gaudio PD, Sansone F, Russo P. Poly(vinyl alcohol) 3D printed tablets: The effect of polymer particle size on drug loading and process efficiency. *International Journal of Pharmaceutics*. 2019;561:1–8.
66. Novák M, Boleslavská T, Grof Z, Waněk A, Zdražil A, Beránek J, et al. Virtual Prototyping and Parametric Design of 3D-Printed Tablets Based on the Solution of Inverse Problem. *AAPS PharmSciTech*. 2018 Nov;19(8):3414–24.
67. Chai X, Chai H, Wang X, Yang J, Li J, Zhao Y, et al. Fused Deposition Modeling (FDM) 3D Printed Tablets for Intra-gastric Floating Delivery of Domperidone. *Sci Rep*. 2017 06;7(1).

68. Matijašić G, Gretić M, Kezerić K, Petanjek J, Vukelić E. Preparation of Filaments and the 3D Printing of Dronedaronone HCl Tablets for Treating Cardiac Arrhythmias. *AAPS PharmSciTech*. 2019 Nov;20(8):310.
69. Alhijaj M, Belton P, Qi S. An investigation into the use of polymer blends to improve the printability of and regulate drug release from pharmaceutical solid dispersions prepared via fused deposition modeling (FDM) 3D printing. *European Journal of Pharmaceutics and Biopharmaceutics*. 2016;108:111–25.
70. Melocchi A, Parietti F, Maroni A, Foppoli A, Gazzaniga A, Zema L. Hot-melt extruded filaments based on pharmaceutical grade polymers for 3D printing by fused deposition modeling. *International Journal of Pharmaceutics*. 2016 Jul 25;509(1):255–63.
71. Li Q, Wen H, Jia D, Guan X, Pan H, Yang Y, et al. Preparation and investigation of controlled-release glipizide novel oral device with three-dimensional printing. *International Journal of Pharmaceutics*. 2017;525(1):5–11.
72. Solanki NG, Tahsin M, Shah AV, Serajuddin ATM. Formulation of 3D Printed Tablet for Rapid Drug Release by Fused Deposition Modeling: Screening Polymers for Drug Release, Drug-Polymer Miscibility and Printability. *Journal of Pharmaceutical Sciences*. 2018;107(1):390–401.
73. Sadia M, Arafat B, Ahmed W, Forbes RT, Alhnan MA. Channelled tablets: An innovative approach to accelerating drug release from 3D printed tablets. *J Control Release*. 2018 Jan 10;269:355–63.
74. Sadia M, Isreb A, Abbadi I, Isreb M, Aziz D, Selo A, et al. From 'fixed dose combinations' to 'a dynamic dose combiner': 3D printed bi-layer antihypertensive tablets. *Eur J Pharm Sci*. 2018 Oct 15;123:484–94.
75. Gioumouxouzis CI, Katsamenis OL, Bouropoulos N, Fatouros DG. 3D printed oral solid dosage forms containing hydrochlorothiazide for controlled drug delivery. *Journal of Drug Delivery Science and Technology*. 2017;40:164–71.

76. Yang Y, Wang H, Li H, Ou Z, Yang G. 3D printed tablets with internal scaffold structure using ethyl cellulose to achieve sustained ibuprofen release. *Eur J Pharm Sci.* 2018 Mar 30;115:11–8.
77. Scoutaris N, Ross SA, Douroumis D. 3D Printed ‘Starmix’ Drug Loaded Dosage Forms for Paediatric Applications. *Pharm Res.* 2018 Jan 16;35(2).
78. Öblom H, Zhang J, Pimparade M, Speer I, Preis M, Repka M, et al. 3D-Printed Isoniazid Tablets for the Treatment and Prevention of Tuberculosis—Personalized Dosing and Drug Release. *AAPS PharmSciTech.* 2019 Feb;20(2):52.
79. Kimura S, Ishikawa T, Iwao Y, Itai S, Kondo H. Fabrication of Zero-Order Sustained-Release Floating Tablets *via* Fused Depositing Modeling 3D Printer. *Chem Pharm Bull.* 2019 Sep 1;67(9):992–9.
80. Pereira BC, Isreb A, Forbes RT, Dores F, Habashy R, Petit J-B, et al. ‘Temporary Plasticiser’: A novel solution to fabricate 3D printed patient-centred cardiovascular ‘Polypill’ architectures. *European Journal of Pharmaceutics and Biopharmaceutics.* 2019 Feb 1;135:94–103.
81. Fuenmayor E, O’Donnell C, Gately N, Doran P, Devine DM, Lyons JG, et al. Mass-customization of oral tablets via the combination of 3D printing and injection molding. *International Journal of Pharmaceutics.* 2019;569:118611.
82. Nukala PK, Palekar S, Patki M, Patel K. Abuse Deterrent Immediate Release Egg-Shaped Tablet (Egglets) Using 3D Printing Technology: Quality by Design to Optimize Drug Release and Extraction. *AAPS PharmSciTech.* 2019 Feb;20(2):80.
83. Gioumouxouzis CI, Baklavaridis A, Katsamenis OL, Markopoulou CK, Bouropoulos N, Tzetzis D, et al. A 3D printed bilayer oral solid dosage form combining metformin for prolonged and glimepiride for immediate drug delivery. *European Journal of Pharmaceutical Sciences.* 2018;120:40–52.

84. Verstraete G, Samaro A, Grymonpré W, Vanhoorne V, Snick BV, Boone MN, et al. 3D printing of high drug loaded dosage forms using thermoplastic polyurethanes. *International Journal of Pharmaceutics*. 2018;536(1):318–25.
85. Kempin W, Domsta V, Brecht I, Semmling B, Tillmann S, Weitschies W, et al. Development of a dual extrusion printing technique for an acid- and thermo-labile drug. *European Journal of Pharmaceutical Sciences*. 2018;123:191–8.
86. Kempin W, Domsta V, Grathoff G, Brecht I, Semmling B, Tillmann S, et al. Immediate Release 3D-Printed Tablets Produced Via Fused Deposition Modeling of a Thermo-Sensitive Drug. *Pharm Res*. 2018 Apr 20;35(6).
87. Zhang J, Yang W, Vo AQ, Feng X, Ye X, Kim DW, et al. Hydroxypropyl methylcellulose-based controlled release dosage by melt extrusion and 3D printing: Structure and drug release correlation. *Carbohydrate Polymers*. 2017 Dec 1;177:49–57.
88. Ehtezazi T, Algellay M, Islam Y, Roberts M, Dempster NM, Sarker SD. The Application of 3D Printing in the Formulation of Multilayered Fast Dissolving Oral Films. *Journal of Pharmaceutical Sciences*. 2018;107(4):1076–85.
89. Goyanes A, Robles Martinez P, Buanz A, Basit AW, Gaisford S. Effect of geometry on drug release from 3D printed tablets. *International Journal of Pharmaceutics*. 2015;494(2):657–63.
90. Goyanes A, Kobayashi M, Martínez-Pacheco R, Gaisford S, Basit AW. Fused-filament 3D printing of drug products: Microstructure analysis and drug release characteristics of PVA-based caplets. *International Journal of Pharmaceutics*. 2016;514(1):290–5.
91. Goyanes A, Fina F, Martorana A, Sedough D, Gaisford S, Basit AW. Development of modified release 3D printed tablets (printlets) with pharmaceutical excipients using additive manufacturing. *International Journal of Pharmaceutics*. 2017;527(1):21–30.
92. Prasad E, Islam MT, Goodwin DJ, Megarry AJ, Halbert GW, Florence AJ, et al. Development of a hot-melt extrusion (HME) process to produce drug loaded

- Affinisol™ 15LV filaments for fused filament fabrication (FFF) 3D printing. *Additive Manufacturing*. 2019;29:100776.
93. Lamichhane, Park, Sohn, Lee. Customized Novel Design of 3D Printed Pregabalin Tablets for Intra-Gastric Floating and Controlled Release Using Fused Deposition Modeling. *Pharmaceutics*. 2019 Oct 30;11(11):564.
 94. Gültekin HE, Tort S, Acartürk F. An Effective Technology for the Development of Immediate Release Solid Dosage Forms Containing Low-Dose Drug: Fused Deposition Modeling 3D Printing. *Pharm Res*. 2019 Sep;36(9):128.
 95. Kollamaram G, Croker DM, Walker GM, Goyanes A, Basit AW, Gaisford S. Low temperature fused deposition modeling (FDM) 3D printing of thermolabile drugs. *International Journal of Pharmaceutics*. 2018;545(1):144–52.
 96. Okwuosa TC, Stefaniak D, Arafat B, Isreb A, Wan K-W, Alhnan MA. A Lower Temperature FDM 3D Printing for the Manufacture of Patient-Specific Immediate Release Tablets. *Pharm Res*. 2016;33(11):2704–12.
 97. Tan DK, Maniruzzaman M, Nokhodchi A. Development and Optimisation of Novel Polymeric Compositions for Sustained Release Theophylline Caplets (PrintCap) via FDM 3D Printing. *Polymers*. 2019 Dec 21;12(1):27.
 98. Sadia M, Sośnicka A, Arafat B, Isreb A, Ahmed W, Kelarakis A, et al. Adaptation of pharmaceutical excipients to FDM 3D printing for the fabrication of patient-tailored immediate release tablets. *International Journal of Pharmaceutics*. 2016;513(1–2):659–68.
 99. Korte C, Quodbach J. Formulation development and process analysis of drug-loaded filaments manufactured via hot-melt extrusion for 3D-printing of medicines. *Pharm Dev Technol*. 2018 Dec;23(10):1117–27.
 100. Isreb A, Baj K, Wojsz M, Isreb M, Peak M, Alhnan MA. 3D printed oral theophylline doses with innovative ‘radiator-like’ design: Impact of polyethylene oxide (PEO) molecular weight. *International Journal of Pharmaceutics*. 2019;564:98–105.

101. Arafat B, Wojsz M, Isreb A, Forbes RT, Isreb M, Ahmed W, et al. Tablet fragmentation without a disintegrant: A novel design approach for accelerating disintegration and drug release from 3D printed cellulosic tablets. *European Journal of Pharmaceutical Sciences*. 2018;118:191–9.
102. Arafat B, Qinna N, Cieszynska M, Forbes RT, Alhnan MA. Tailored on demand anti-coagulant dosing: An in vitro and in vivo evaluation of 3D printed purpose-designed oral dosage forms. *European Journal of Pharmaceutics and Biopharmaceutics*. 2018;128:282–9.
103. Wang S, Capoen L, D'hooge D, Cardon L. Can the melt flow index be used to predict the success of fused deposition modelling of commercial poly(lactic acid) filaments into 3D printed materials? *Plastics, Rubber and Composites*. 2017 Nov 10;47:1–8.
104. Zawaski CE, Wilts EM, Chatham CA, Stevenson AT, Pekkanen AM, Li C, et al. Tuning the material properties of a water-soluble ionic polymer using different counterions for material extrusion additive manufacturing. *Polymer*. 2019;176:283–92.
105. Nasereddin JM, Wellner N, Alhijaj M, Belton P, Qi S. Development of a Simple Mechanical Screening Method for Predicting the Feedability of a Pharmaceutical FDM 3D Printing Filament. *Pharm Res*. 2018 May 31;35(8):151.
106. Wojtyła S, Klama P, Baran T. Is 3D printing safe? Analysis of the thermal treatment of thermoplastics: ABS, PLA, PET, and nylon. *Journal of Occupational and Environmental Hygiene*. 2017 Jun 3;14(6):D80–5.
107. Deng Y, Cao S-J, Chen A, Guo Y. The impact of manufacturing parameters on submicron particle emissions from a desktop 3D printer in the perspective of emission reduction. *Building and Environment*. 2016;104:311–9.
108. ZHANG S, THOMASSON A, MESBAH B, GUERNION PY, PIN F, ALEIXO T, et al. LA SURVEILLANCE DES PARTICULES ULTRAFINES EN FRANCE. 2018 [cited 2020 May 26]; Available from: http://www.asfera.org/fr/textes-scientifiques/la-surveillance-des-particules-ultrafines-en-france/tex_id/23

109. House R, Rajaram N, Tarlo SM. Case report of asthma associated with 3D printing. *Occup Med (Lond)*. 2017 Dec 2;67(8):652–4.
110. Chan FL, House R, Kudla I, Lipszyc JC, Rajaram N, Tarlo SM. Health survey of employees regularly using 3D printers. *Occupational Medicine*. 2018 May 17;68(3):211–4.
111. Short DB, Sirinterlikci A, Badger P, Artieri B. Environmental, health, and safety issues in rapid prototyping. *Rapid Prototyping Journal*. 2015 Jan 1;21(1):105–10.
112. Hoek G, Boogaard H, Knol A, de Hartog J, Slottje P, Ayres JG, et al. Concentration Response Functions for Ultrafine Particles and All-Cause Mortality and Hospital Admissions: Results of a European Expert Panel Elicitation. *Environmental Science & Technology*. 2010;44(1):476–82.
113. Azimi P, Zhao D, Pouzet C, Crain NE, Stephens B. Emissions of Ultrafine Particles and Volatile Organic Compounds from Commercially Available Desktop Three-Dimensional Printers with Multiple Filaments. *Environ Sci Technol*. 2016 Feb 2;50(3):1260–8.
114. Awad A, Trenfield SJ, Goyanes A, Gaisford S. Reshaping drug development using 3D printing. *Drug Discovery Today [Internet]*. 2018; Available from: <http://linkinghub.elsevier.com/retrieve/pii/S1359644617305391>
115. Goyanes A, Scarpa M, Kamlow M, Gaisford S, Basit AW, Orlu M. Patient acceptability of 3D printed medicines. *International Journal of Pharmaceutics*. 2017;530(1–2):71–8.
116. Christensen ML, Chesney RW, Helms RA. Clinical Trial Design and Alterations in Drug Disposition with Age. *Ther Innov Regul Sci*. 2000 Jan 1;34(1):157–63.
117. Minghetti P, Pantano D, Gennari CGM, Casiraghi A. Regulatory framework of pharmaceutical compounding and actual developments of legislation in Europe. *Health Policy*. 2014 Sep 1;117(3):328–33.

118. reflection-paper-formulations-choice-paediatric-population_en.pdf [Internet]. [cited 2020 Apr 18]. Available from: https://www.ema.europa.eu/en/documents/scientific-guideline/reflection-paper-formulations-choice-paediatric-population_en.pdf
119. Lim SH, Kathuria H, Tan JJY, Kang L. 3D printed drug delivery and testing systems — a passing fad or the future? *Advanced Drug Delivery Reviews* [Internet]. 2018 May 18; Available from: <http://www.sciencedirect.com/science/article/pii/S0169409X18301091>
120. Zema L, Melocchi A, Maroni A, Gazzaniga A. Three-Dimensional Printing of Medicinal Products and the Challenge of Personalized Therapy. *Journal of Pharmaceutical Sciences*. 2017;106(7):1697–705.
121. Pramod K, Tahir MA, Charoo NA, Ansari SH, Ali J. Pharmaceutical product development: A quality by design approach. *Int J Pharm Investig*. 2016;6(3):129–38.
122. Anonymous. Quality by design [Internet]. European Medicines Agency. 2018. Available from: <https://www.ema.europa.eu/en/human-regulatory/research-development/quality-design>
123. Abraham J. International Conference On Harmonisation Of Technical Requirements For Registration Of Pharmaceuticals For Human Use. In: Brouder A, Tietje C, editors. *Handbook of Transnational Economic Governance Regimes* [Internet]. Brill; 2009 [cited 2019 Mar 29]. p. 1041–54. Available from: <http://booksandjournals.brillonline.com/content/books/10.1163/ej.9789004163300.i-1081.897>
124. Yu LX. Pharmaceutical Quality by Design: Product and Process Development, Understanding, and Control. *Pharm Res*. 2008 Apr 1;25(4):781–91.
125. Chavan SD, Pimpodkar NV, Kadam AS, S.Gaikwad P. Quality by Design. *Research & Reviews: Journal of Pharmaceutical Quality Assurance*. 2015 Nov 5;1(2):18–22.

