



HAL
open science

International Journal of Radiation Biology Is static magnetic field exposure a new model of metabolic alteration? Comparison with Zucker rats

Miryam Elferchichi, Jacques Mercier, Annick Bourret, René Gross, Anne-Dominique Lajoix, Hatem Belguith, Hamed Abdelmelek, Mohsen Sakly, Karen Lambert

► To cite this version:

Miryam Elferchichi, Jacques Mercier, Annick Bourret, René Gross, Anne-Dominique Lajoix, et al.. International Journal of Radiation Biology Is static magnetic field exposure a new model of metabolic alteration? Comparison with Zucker rats. International Journal of Radiation Biology, 2011, 87 (5), pp.483-490. 10.3109/09553002.2011.544371 . hal-02540640

HAL Id: hal-02540640

<https://hal.umontpellier.fr/hal-02540640>

Submitted on 11 Apr 2020

HAL is a multi-disciplinary open access archive for the deposit and dissemination of scientific research documents, whether they are published or not. The documents may come from teaching and research institutions in France or abroad, or from public or private research centers.

L'archive ouverte pluridisciplinaire **HAL**, est destinée au dépôt et à la diffusion de documents scientifiques de niveau recherche, publiés ou non, émanant des établissements d'enseignement et de recherche français ou étrangers, des laboratoires publics ou privés.

Is static magnetic field exposure a new model of metabolic alteration? Comparison with Zucker rats

Miryam Elferchichi, Jacques Mercier, Annick Bourret, René Gross, Anne-Dominique Lajoix, Hatem Belguith, Hamed Abdelmelek, Mohsen Sakly & Karen Lambert

To cite this article: Miryam Elferchichi, Jacques Mercier, Annick Bourret, René Gross, Anne-Dominique Lajoix, Hatem Belguith, Hamed Abdelmelek, Mohsen Sakly & Karen Lambert (2011) Is static magnetic field exposure a new model of metabolic alteration? Comparison with Zucker rats, DOI: [10.3109/09553002.2011.544371](https://doi.org/10.3109/09553002.2011.544371)

Is static magnetic field exposure a new model of metabolic alteration? Comparison with Zucker rats

MIRYAM ELFERCHICHI^{1,2,3}, JACQUES MERCIER^{2,3}, ANNICK BOURRET^{2,3},
RENÉ GROSS⁴, ANNE-DOMINIQUE LAJOIX⁴, HATEM BELGUITH¹,
HAFEDH ABDELMELEK¹, MOHSEN SAKLY¹, & KAREN LAMBERT^{2,3}

¹Faculté des Sciences de Bizerte, Laboratoire de Physiologie Intégrée, Jarzouna, Tunisia, ²INSERM, ERI25, "Muscle and Pathologies", Montpellier, ³Université Montpellier I, Montpellier, and ⁴CNRS UMR5232, UM1, Centre for Pharmacology and Innovation in Diabetes, Montpellier, France

Abstract

Purpose: The aim of this study was to investigate if the metabolic alterations observed after static magnetic field (SMF) exposure participates in the development of a pre-diabetic state. A comparison study using the insulin resistant animal model, the Zucker rat and the SMF-exposed Wistar rat was carried out.

Materials and methods: Zucker rats were compared to Wistar rats either exposed to a 128 mT or 0 mT SMF (sham exposed) and analysed. This moderate-intensity SMF exposure of Wistar rats was performed for 1 h/day during 15 consecutive days.

Results: Wistar rats exposed to the SMF showed increased levels of carbohydrate and lipid metabolites (i.e., lactate, glycerol, cholesterol and phospholipids) compared to sham-exposed rats. Zucker rats displayed a normoglycemia associated with a high insulin level as opposed to Wistar rats which presented hyperglycemia and hypoinsulinemia after exposure to the SMF. During the glucose tolerance test, unexposed Zucker rats and Wistar rats exposed to the SMF exhibited a significantly higher hyperglycemia compared to sham-exposed Wistar rats suggesting an impairment of glucose clearance. In muscle, glycogen content was lower and phospholipids content was elevated for both unexposed Zucker rats and Wistar rats exposed to the SMF compared to Wistar rats sham control.

Conclusions: This study provides evidence that the metabolic alterations following exposure to a static magnetic field of moderate intensity could trigger the development of a pre-diabetic state.

Keywords: *adaptive response, biochemistry, E-M fields*

Introduction

According to their frequency, electric and magnetic fields (EMF) are classified into static, extremely low frequency, intermediate frequency and radiofrequency fields. Static magnetic fields (SMF) are characterised by a frequency of 0 Hertz (Hz) and a field which does not vary with time (Repacholi and Greenebaum 1999). SMF are naturally present everywhere as the earth is surrounded by fields that vary between 25 and 65 μ T (Feychting 2005). Superimposed on the earth's magnetic field are man-made static magnetic fields resulting in an increase of people exposed to SMF. Moreover, SMF are widely used in the treatment of musculoskeletal pain relief (Pilla 2006), refractory neuro-

pathic pain (Weintraub and Cole 2004) and symptomatic diabetic neuropathy (Weintraub et al. 2003).

Compelling evidence exists that SMF modulate living systems (Repacholi and Greenebaum 1999, Havas 2000, World Health Organisation [WHO] 2006, Okano 2008). Thus, SMF can affect a wide range of biological systems and tissues as a result of moderate SMF (Rosen 2003a, Dini and Abbro 2005, Amara et al. 2006, Chater et al. 2006) to high intensity SMF (Iwasaka and Ueno 1994, High et al. 2000, Kotani et al. 2002, Ueno and Shigemitsu 2007). SMF can interact with moving charges or ferromagnetic materials and biological molecules with particular magnetic properties (haemoglobin, free radicals) presumably via two mechanisms: The

Correspondence: Mrs Karen Lambert, PhD, INSERM ERI25, Bâtiment Crastes de Paulet, Hôpital A. de Villeneuve, 34 295 Montpellier Cedex 5, France.
Tel: + 33(4) 6741 5230. Fax: + 33(4) 6741 5231. E-mail: karen.lambert@univ-montp1.fr

radical pair mechanism and the membrane transducer mechanism. The former hypothesis assumes that SMF increase the lifetime of reactive oxygen species (ROS) and thus their cellular concentrations. These effects are amplified by combined exposure to toxic agents (Amara et al. 2009). Several studies have investigated the effect of SMF on oxidative stress caused by an imbalance between ROS generation and antioxidant capacity of the cell and the consequences of this stress (Zhang et al. 2003, Bekhite et al. 2010). As recently reviewed, there is ROS modulation by moderate SMF exposure with large variations depending on the models studied, the intensity of exposure and the tissues targeted (Okano 2008). The second hypothesis is based on reports that SMF can change the biophysical properties of membranes (Rosen 2003b, Genius 2008) leading to an alteration in calcium homeostasis, an increase in membrane rigidity and/or activation of at least nine different signaling networks (Wang et al. 2009). These two hypotheses give insights as to how SMF have the potential to induce metabolic alterations.

However, not much is known about the possible effects of SMF on *in vivo* metabolism. For instance, Gorczynska and Wegrzynowicz (1991) and Chater et al. (2006) observed a temporary diabetic-like response (i.e., increased blood glucose) in rats exposed to constant magnetic fields. On the other hand, Bellossi (1992) and Bellossi et al. (1996) and Öcal et al. (2008) have demonstrated a reduction in blood glucose levels after exposure to pulsed magnetic fields and alternating magnetic fields, respectively. Finally, a recent study illustrated that in addition to type 1 diabetes characterised by insufficient insulin production, and type 2 diabetes where the insulin produced is ineffectively used, a third type of diabetes may be environmentally exacerbated or induced by exposure to electromagnetic fields (Havas 2008).

Thus, we hypothesised that the metabolic alterations immersing after SMF exposure could participate in the development of a pre-diabetic state. In an attempt to test this hypothesis, we compared the effects of SMF exposure of the Wistar rat to Wistar rat sham controls and the Zucker rat, which is a well-known insulin resistant animal model.

Materials and methods

Animals and protocol

Male Wistar rats ($n=12$) (Pasteur Institute, Tunis, Tunisia) and male Zucker rats (Janvier, Le Genest-Saint-Isle, France) were housed in a temperature-controlled room at 25°C under a 12 h/12 h light/dark cycle, with free access to a standard diet and water. Wistar rats were randomly divided into the following

groups: exposed rats ($n=6$) to SMF (128 mT; 1h/day) for 15 consecutive days and sham-exposed control rats ($n=6$) placed in the Lake Shore Electromagnetic processor (1h/day) for 15 consecutive days but not exposed to SMF (0 mT). Animals were cared for in compliance to the Tunisian code of practice for the “Care and Use of Animals for Scientific Purposes”. The experimental protocols were approved by the Faculty Ethics Committee. Faculté des Sciences de Bizerte, Tunisia.

Exposure system

We used an electromagnet (Model EM4-HVA, Lake Shore Cryotronic Inc., Westerville, OH, USA) charged by a magnet power supply (Model 647, Lake Shore Cryotronic Inc., Westerville, OH USA) containing an air gap of 11 cm (Figure 1). This apparatus incorporates water-cooled coils and precision yokes that assure precise cap alignment and excellent field stability and uniformity when high power is required to achieve the maximum field capability for the electromagnet. SMF intensity was measured and standardised over the total floor area of the Plexiglas cage at 128 mT. SMF uniformity in the active exposure volume was $\pm 0.2\%$ over 1 cm³. The experimental cage measured 20 × 10 × 20 cm. The two bobbins of the Lake Shore electromagnet were separated by a 12.1 cm gap. Exposed and sham control rats ($n=2$ /each time) were placed in the cage at the center of the uniform field area and exposed, or not, to 128 mT SMF. This intensity was chosen according to previous data of our laboratory which revealed that 128 mT was the minimal intensity for inducing alterations of physiological parameters (Abdelmelek et al. 2000, 2001, 2006, Chater et al. 2006).

Intraperitoneal glucose tolerance test (IPGTT)

Two days before being sacrificed, rats underwent an intraperitoneal glucose tolerance test (IPGTT), as previously described (Metz et al. 2005). Briefly, after 4 h of fasting, a glucose solution (2 g/kg body weight) was administered intraperitoneally (i.p.). Blood was collected 0, 20, 40, 60 and 90 min after i.p. glucose administration for consequent measurements of glucose and insulin plasma levels.

Biochemical analysis

Zucker rats and Wistar rats, exposed or sham exposed, were sacrificed by decapitation while in a post prandial state. Blood samples were immediately centrifuged and plasma aliquots were frozen and stored at -80°C until further use. Plasma glucose concentration was measured using the enzymatic

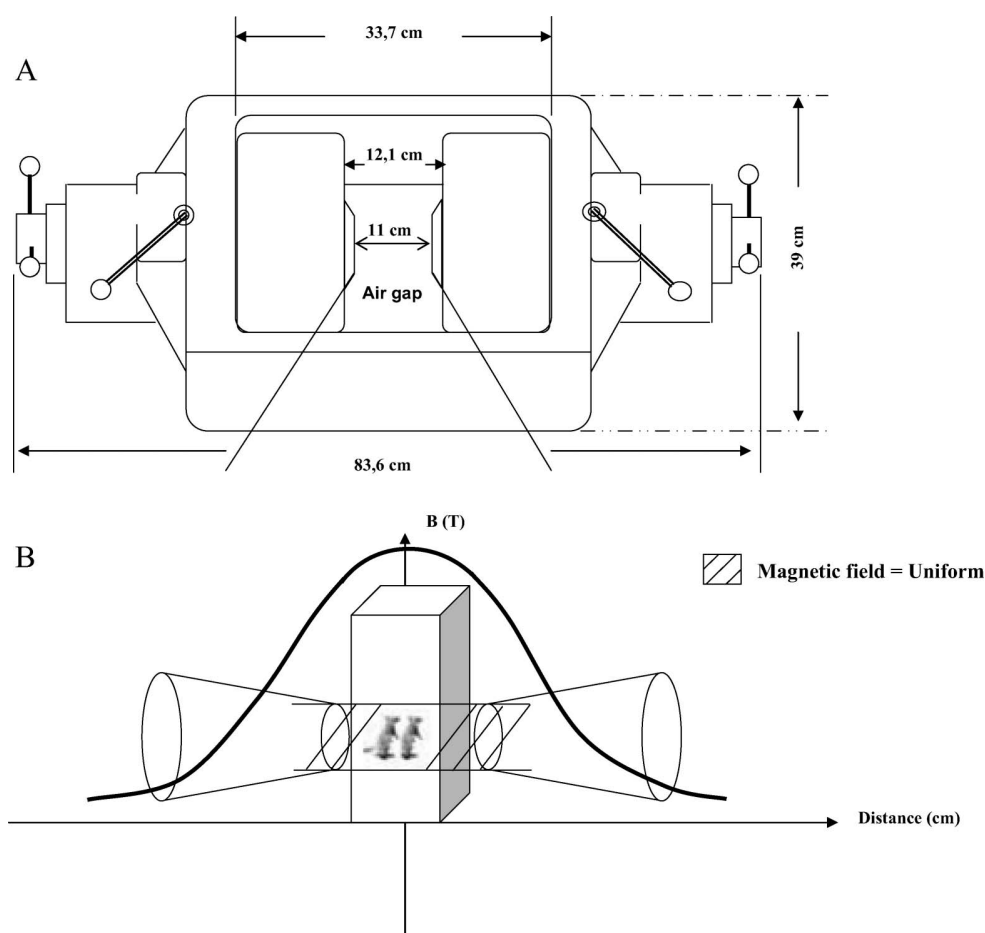

Figure 1. Model EM4-HVA Electromagnet dimensions (Front view) (A) and magnetic field propagation (B). $B(T)$ = Magnetic induction.

method (Sigma 510, St-Quentin Fallavier, France), triglyceride and glycerol content were quantified by the Serum Triglycerides Determination Kit (Sigma TR0100, St-Quentin Fallavier, France). Insulin concentration was determined by radioimmunoassay following manufacturer's instructions (SRI-13K, Labodia, Paris, France). We used a colorimetric enzymatic test for cholesterol analysis (CHOD-PAP, Biomagrheb 20111, Ariana, Tunisia). For lactate assay, a 50 μ l blood sample aliquot was immediately mixed with 200 μ l of ice-cold 7% perchloric acid and centrifuged at 1500 g for 10 min at +4°C. The supernatant was analysed enzymatically for lactate content according to the method of Gutmann and Wahlefeld (Gutmann and Wahlefeld 1974). Phospholipids were analysed according to the method developed by Shibuya et al. (1967). All reagents used were obtained from Sigma (St-Quentin Fallavier, France).

Tissue sampling

Immediately after sacrificing each rat, the soleus (SOL; oxidative muscle) and the extensor digitor-

um longus (EDL; glycolytic muscle) of the hindlimb were removed, frozen in liquid nitrogen and stored at -80°C until use for various enzymatic activity measurements. Quadriceps and liver biopsies were carried out in order to quantify tissular glycogen, phospholipids, triglycerides and glycerol levels.

Enzymatic activities

Citrate synthase (CS) activity was measured at 412 nm and 30°C for 2.5 min as suggested by Srere (1969). Also, 3-hydroxyacyl-coenzyme A-dehydrogenase (HADH) and lactate dehydrogenase (LDH) activities were measured at 340 nm during 10 min and 2.5 min, respectively. Results are expressed in micromoles per minute per g of tissue weight ($\mu\text{mol}/\text{min}/\text{g}$).

Muscle and liver glycogen contents. Muscle and liver glycogen contents were measured on portions of quadriceps and liver using the procedure described by Lo et al. (1970). Briefly, liver and muscle were

boiled in 30% potassium hydroxide (KOH) saturated with Na_2SO_4 for 30 min to become soluble, and glycogen was then precipitated from the solution by addition of a 1.2 volume of 95% ethanol. Samples were centrifuged for 30 minutes at 840 g and pellets were resuspended in H_2O . Assays were conducted on aliquots in triplicate against appropriate blanks at 490 nm. Results were determined from a standard curve generated at the same time and expressed in mg glycogen.g tissue⁻¹.

Data presentation and statistical analysis. Data were reported as the mean \pm standard error of the mean (SEM). Statistical significance of the differences between mean values was assessed by Student's *t*-test. Differences within groups for the IPGTT values were assessed by analysis of variance (ANOVA) method followed by Bonferroni post hoc tests. The level of significance was set at $p < 0.05$.

Results

Metabolic parameters

Basal metabolic parameters related to carbohydrate and lipid metabolism are reported in Table I. In post prandial state, we observed an increase in glycemia for SMF-exposed Wistar rats and a normoglycemia in unexposed Zucker rats compared to sham-exposed Wistar rats. However, insulin concentration showed a marked difference between hyperinsulinemic Zucker rats and SMF-exposed Wistar rats which on the contrary are hypoinsulinemic. Unexposed Zucker rats and Wistar rats exposed to SMF displayed a significant increase of plasma lactate levels compared to sham-exposed Wistar rats ($p < 0.01$). Additionally, both unexposed Zucker and Wistar SMF-exposed rats presented enhanced plasmatic concentrations of glycerol, cholesterol ($p < 0.01$) and phospholipids ($p < 0.01$) as opposed to triglycerides (TG) levels which were significantly increased only in the Zucker rat group whereas the

Table I. Basal metabolic parameters in sham exposed (C), Static Magnetic Field exposed (SMF), and Zucker (Z) rats.

	C	SMF	Z
Glycemia (mg/dl)	166 \pm 4	206 \pm 6*	152 \pm 8
Insulin (ng/ml)	4.7 \pm 0.1	1.7 \pm 0.5*	11.3 \pm 0.6*
Lactate (mM)	1.4 \pm 0.1	3.2 \pm 0.4**	2.8 \pm 0.2**
Triglycerides (mg/dl)	66 \pm 11	47 \pm 9	116 \pm 15*
Glycerol (mg/dl)	14 \pm 3	23 \pm 5*	44 \pm 16**
Cholesterol (g/l)	1.0 \pm 0.1	1.3 \pm 0.1**	1.8 \pm 0.1**
Phospholipids (mg/ml)	1.0 \pm 0.1	1.6 \pm 0.1**	2.06 \pm 0.6**

Data represent the means \pm SEM of six animals per group. * $p < 0.05$; ** $p < 0.01$ significantly different from sham exposed (C).

SMF-exposed Wistar rat group showed no alteration in TG levels compared to sham-exposed animals.

Intraperitoneal glucose tolerance test responses (IPGTT)

To investigate whole body glucose metabolism, the intraperitoneal glucose tolerance test (IPGTT) was performed on fasted animals two days prior to their sacrifice (Figure 2A). Intraperitoneal administration of glucose resulted in an increase of plasma glucose and insulin concentrations in all groups. ANOVA analysis showed that overall, unexposed Zucker rats and Wistar rats exposed to SMF had higher glucose levels than sham-exposed animals. Therefore, the period of hyperglycemia was longer for SMF-exposed Wistar and Zucker rats than in sham-exposed rats suggesting an impairment of glucose clearance. These higher glucose levels detected in SMF-exposed Wistar rats were accompanied by

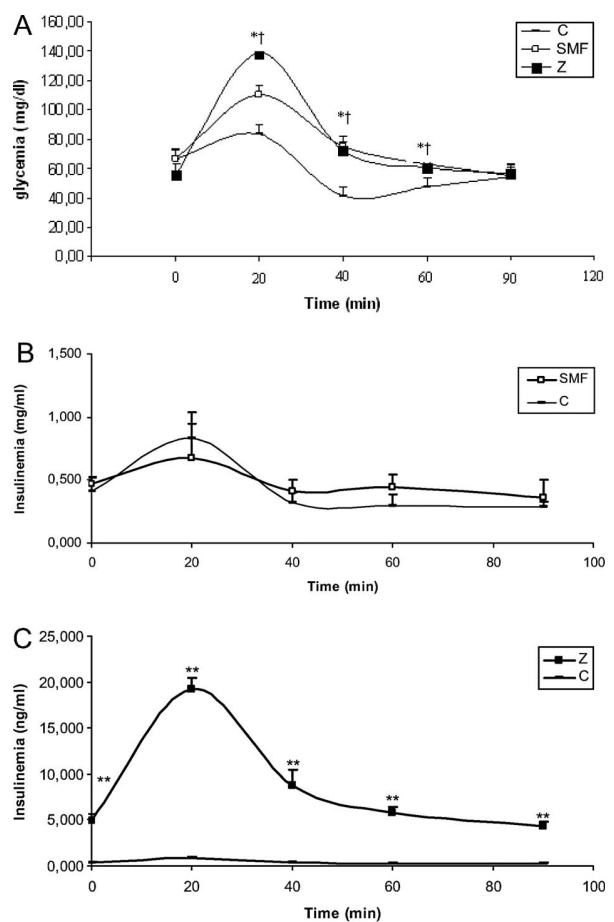

Figure 2. (A) Glucose response to an IPGTT in sham exposed (C), Zucker (Z) and SMF-exposed rats (SMF). (B) Insulin response to an IPGTT in sham exposed (C) and SMF-exposed rats (SMF). (C) Insulin response to an IPGTT in sham exposed (C) and Zucker (Z). Error bars indicate the standard error of the mean (SEM) for $n = 4-6$ independent experiments. * $p < 0.05$ vs. C, ** $p < 0.01$ vs. C.

insulin levels that were similar to those observed in sham-exposed animals (Figure 2B), while in Zucker rats insulin response was higher than those of sham- and SMF-exposed Wistar rats (Figure 2C).

Muscular and hepatic biopsies parameters

Since skeletal muscle and liver play a crucial role in glucose and lipid metabolism, we analysed some of their metabolic parameters (Table II). In muscle, SMF-exposed Wistar rats and unexposed Zucker rats displayed both a decrease in glycogen content and an increase in phospholipid content without alteration in triglyceride and glycerol levels compared to the Wistar rat sham control. In liver, phospholipid concentrations increase only in SMF-exposed rats without any modification of glycerol and triglyceride levels for both Wistar sham-exposed and Zucker rat groups. Hepatic glycogen content was unaffected in Zucker rats whereas in Wistar rats SMF exposure induces a 25% decrease compared to Wistar sham control rats.

Enzymatic activities in oxidative and glycolytic muscle biopsies

To further analyse possible metabolic effects of SMF, we studied the activities of glycolytic and oxidative enzymes in both oxidative and glycolytic muscles. We consequently tested CS, HADH and LDH activities in the soleus (SOL; oxidative muscle) and the extensor digitorum longus (EDL; glycolytic muscle) of both animal groups (Figure 3). For the three enzymes tested, we obtained different metabolic responses between animal groups dependent on muscle type. In fact, although SMF-exposed Wistar rats had a lower CS activity in their EDL muscle, this activity was higher in unexposed Zucker rats for both muscles. On the other hand, SMF exposure to Wistar rats increased LDH activity (Figure 3B) only in the EDL muscle but no differences in LDH activity occurred in either muscle for Zucker rats compared to the sham-exposed group. Finally, HADH activity (Figure 3C) remained unchanged in both EDL and SOL muscles after Wistar rat SMF exposure, whereas its activity was higher only in the SOL muscles of unexposed Zucker rats.

Discussion

The major finding of this study is that metabolic disorders following exposure to a 128 mT static magnetic fields in Wistar rats were similar to those observed in unexposed Zucker rats.

In the present study, our moderate intensity exposure level is well above the level of natural environmental SMF exposure or the SMF intensity used for pain relief but well below the intensity employed for magnetic resonance imaging. However, this moderate intensity is powerful enough to induce important metabolic alterations favouring the development of a pre-diabetic state involving some characteristics of both type 1 and type 2 diabetes.

Glucose tolerance testing allows the investigation of carbohydrate metabolism. We firstly note that the glucose levels of both SMF exposed Wistar and unexposed Zucker rats are higher compared to sham-exposed Wistar rats. Secondly, insulin response to glucose charge was higher in Zucker rats, whereas SMF exposure did not induce any noted difference compared to sham-exposed Wistar rats. These data suggest impairment in glucose clearance and/or insulin alteration. Indeed, Li et al. (2005) found an alteration in insulin binding to its hepatocyte receptors after pulsed electric field exposure. They also noted conformational changes in the insulin molecule itself, associated with an 87% reduction in the insulin binding capacity to its receptors compared with control groups. Recently, Chen et al. (2010) showed that electromagnetic pulse (EMP) exposure decreased the bioactivity of insulin in type 1 diabetic mice due to a decreased binding affinity between insulin and its receptor. This mechanism could involve a conformational insulin alteration due to EMP exposure as already noticed by Budi et al. (2008). These studies underline sensitivity of insulin to magnetic field exposure. Further investigations are needed to determine the effect of SMF exposure on insulin structure. Despite the relevance of these speculations, we cannot exclude the possible involvement of stress. Stress often increases plasma glucose levels while insulin release is strongly inhibited by norepinephrine (Avignon and Monnier 2001). Indeed, this is supported by the finding of Abdelmelek et al. (2006) who reported higher norepinephrine levels in skeletal muscle of rats after

Table II. Muscular and hepatic parameters in sham exposed (C), Static Magnetic Field exposed (SMF), and Zucker (Z) rats.

	C	Liver SMF	Z	C	Muscle SMF	Z
Glycogen (mg of gly/g tissue)	33 ± 3	25 ± 2*	35 ± 5	5.7 ± 0.5	3.2 ± 0.3**	0.8 ± 0.1**
Phospholipides (mg/g tissue)	17 ± 0.6	20 ± 0.3**	15 ± 0.5	13 ± 0.7	18 ± 1.2**	22 ± 3**
Triglycerides (mg/dl)	103 ± 12	118 ± 10	121 ± 12	20 ± 2	22 ± 1	17 ± 4
Glycerol (mg/dl)	99 ± 14	110 ± 11	116 ± 11	19 ± 2	21 ± 1	16 ± 4

Data represent the means ± SEM of six animals per groups. * $p < 0.05$; ** $p < 0.01$ significantly different from sham exposed rats (C).

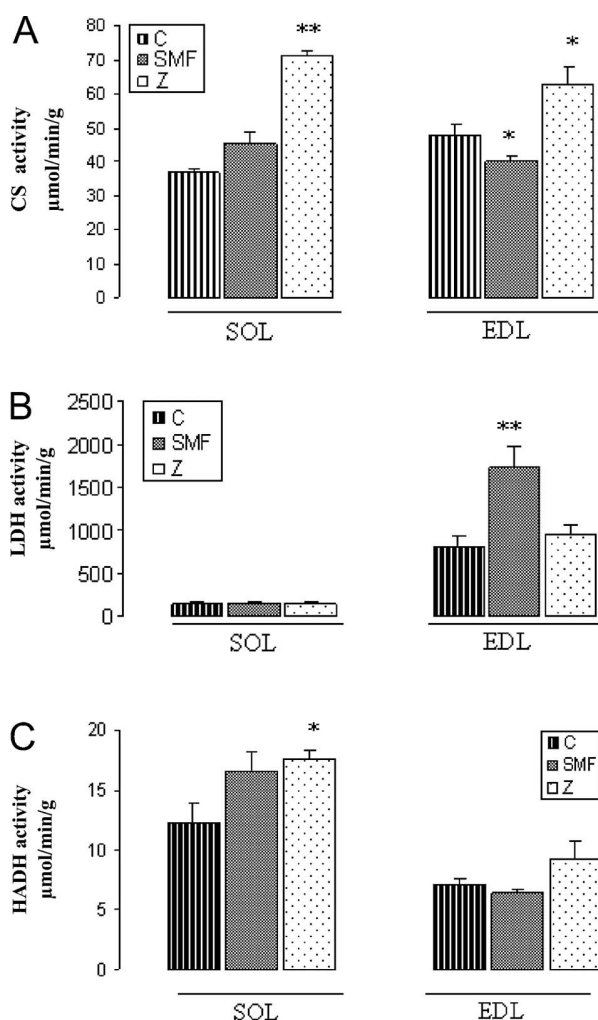

Figure 3. Citrate synthase activity (A), Lactate dehydrogenase activity (B), and Hydroxyl-acyl CoA-deshydrogenase activity (C) in Soleus (SOL) and Extensor Digitorum Longus (EDL) in sham exposed (C), SMF-exposed rat (SMF), and Zucker (Z) groups. Error bars indicate the standard error of the mean (SEM) for $n = 6$ independent experiments. * $p < 0.05$ vs. C, ** $p < 0.01$ vs. C.

SMF exposure at 128 mT. Navakatikyan et al. (1994) had previously measured serum insulin levels after daily 23 h exposure to magnetic fields of 50 Hz at 10, 50, and 250 mT for 11 days. Serum insulin levels were decreased for medium and high-flux magnetic densities when catecholamine levels were increased. Moreover, it is important to note that hyperglycemia could also be due to alterations in other hormones implicated in glucose homeostasis since Gorczynska and Wegrzynowicz (1991) found an increase in glucagon, cortisol, thyroid hormones and growth hormone levels after magnetic field exposure suggesting a diabetic-like state.

Regarding the level of blood lactate, we noticed a strong hyperlactatemia in both unexposed Zucker and Wistar SMF-exposed rats. Previous studies have found a relation between hyperlactatemia and lactate

exchange alterations in the etiology of insulin resistance (Vettor et al. 1997, Lombardi et al. 1999). These alterations were due to both impaired lactate metabolism (Vettor et al. 2000, Miller et al. 2002) and impaired lactate exchange in skeletal muscle (Py et al. 2001, 2002). Thus, the hyperglycemia observed after SMF exposure, could be explained by a reduced glucose uptake due to high lactate levels. The tissues mainly responsible for glucose uptake are skeletal muscles and liver, thus we aimed to evaluate glucose storage in these tissues. Muscular glycogen was reduced in both unexposed Zucker rats and Wistar SMF-exposed rats, whereas a decrease in hepatic glycogen was only observed in Wistar rats following SMF exposure, in accordance with previous findings (Chater et al. 2006). This reduction could be caused either by a decrease in glucose uptake and insulin level or an increase glycogenolysis due to epinephrine (Abdelmelek et al. 2006).

Investigation of enzymatic activity in SMF-exposed rats seems to indicate a shift from oxidative to glycolytic metabolism consistent with previously published studies (Abdelmelek et al. 2006, Chater et al. 2006). It is important to consider that SMF exposure preferably affects glycolytic muscles and favours lactate production. However, unexposed Zucker rats presented an increased muscular oxidative capacity as previously found (Pujol et al. 1993, Dourmashkin et al. 2005).

Since glucose metabolism strongly interacts with lipid metabolism, lipid parameters were also measured. Not counting triglyceride levels which remained unchanged after SMF exposure, a large increase in glycerol, cholesterol and phospholipids levels was noticed in both groups (unexposed Zucker rats and Wistar SMF-exposed rats) compared to sham-exposed Wistar animals. An excess level of circulating lipid is often associated with cardiovascular diseases and participates in the dysregulation of glucose metabolism (Boden and Shulman 2002, Savage et al. 2007).

Conclusion

We propose a block diagram (Table III) which reveals the main similarities between Wistar rats exposed to static magnetic fields and unexposed Zucker rats. These data suggest that the metabolic alterations observed in Wistar rats following SMF exposure were similar in many ways to those obtained in Zucker rats. Our study provides evidence that a 128 mT static magnetic field exposure might favour the development of a pre-diabetic state or at least the emergency of some characteristics found in type 1 and type 2 diabetes. Thus, it seems that in addition to lifestyle and

Table III. Comparison between metabolic alterations observed in Static Magnetic Field exposed (SMF) and Zucker (Z) rats.

	SMF	Z
Systemic: Glucose	↑	=
Insulin	↓	↑
Lactate	↑	↑
Triglycerides	=	↑
Glycerol	↑	↑
Cholesterol	↑	↑
Phospholipids	↑	↑
Liver: Glycogen	↓	=
Phospholipids	↑	=
Muscle: Glycogen	↓	↓
Phospholipids	↑	↑
SOL	=	↑
CS activity		
EDL	↓	↑
SOL	=	=
LDH activity	↑	=
EDL		
SOL	=	↑
HADH activity		
EDL	=	=

↑: Increase; ↓: Decrease; =: No effect; CS activity: Citrate synthase activity; LDH activity: Lactate dehydrogenase activity; HADH activity: 3-hydroxyacyl-coenzyme A-dehydrogenase activity; SOL: soleus oxidative muscle; EDL: Extensor digitorum longus glycolytic muscle.

genetic predisposition, experimental magnetic exposure at moderate intensity fields may be another factor promoting metabolic disorders. These results warrant further investigations to understand the mechanism and signalling pathways involved in these alterations.

Acknowledgements

We would like to thank Marie Hokayem for the critical review of the manuscript.

Declaration of interest: The authors report no conflicts of interest. The authors alone are responsible for the content and writing of the paper.

References

Abdelmelek H, Chater S, Sakly M. 2001. Acute exposure to magnetic field depresses shivering thermogenesis in rat. *Biomedizinische Technik-Band 46-Ergänzungsband 2*:164–166.

Abdelmelek H, Chater S, Smirani R, M'Chirgui A, Ben Jeddou C, Ben Salem M, Sakly M. 2000. Effects of 50Hz sinusoidal waveform magnetic field on dehydrated rat body. *Millennium International Workshop on Biological Effects of Electromagnetic fields*. pp 474–479.

Abdelmelek H, Molnar A, Servais S, Cottet-Emard JM, Pequignot JM, Favier R, Sakly M. 2006. Skeletal muscle HSP72 and norepinephrine response to static magnetic field in rat. *Journal of Neural Transmission* 113:821–827.

Amara S, Abdelmelek H, Garrel C, Guiraud P, Douki T, Ravanat JL, Favier A, Sakly M, Ben Rhouma K. 2006. Effects of subchronic exposure to static magnetic field on testicular function in rats. *Archive of Medical Research* 37: 47–952.

Amara S, Garrel C, Favier A, Ben Rhouma K, Sakly M, Abdelmelek H. 2009. Effect of static magnetic field and/or cadmium in the antioxidant enzymes activity in rat heart and skeletal muscle. *General Physiology and Biophysics* 28:414–419.

Avignon A, Monnier L. 2001. Insulin sensitivity and stress. *Diabetes and Metabolism* 27:233–238.

Bekhte MM, Finkensieper A, Abou-Zaid FA, El-Shourbagy IK, Omar KM, Figulla HR, Sauer H, Wartenberg M. 2010. Static electromagnetic fields induce vasculogenesis and chondro-osteogenesis of mouse embryonic stem cells by reactive oxygen species-mediated up-regulation of vascular endothelial growth factor. *Stem Cells and Development* 19:731–743.

Bellossi A, Pouvreau-Quillien V, Rocher C, Ruelloux M. 1996. Effect of pulsed magnetic fields on cholesterol and triglyceride levels in rats study of field intensity and length of exposure. *Z Naturforsch [C]* 51:603–606.

Bellossi A. 1992. Effects of a 12 Hz and 460 Hz pulsed magnetic field on the weight of AKR mice. *Biotherapy* 4:277–283.

Boden G, Shulman GI. 2002. Free fatty acids in obesity and type 2 diabetes: Defining their role in the development of insulin resistance and beta-cell dysfunction. *European Journal of Clinical Investigation* 32:14–23.

Budi A, Legge FS, Treutlein H, Yarovsky I. 2008. Comparative study of insulin chain-B in isolated and monomeric environments under external stress. *The Journal of Physical Chemistry B* 112:7916–7924.

Chater S, Abdelmelek H, Pequignot JM, Sakly M, Rhouma KB. 2006. Effects of sub-acute exposure to static magnetic field on hematologic and biochemical parameters in pregnant rats. *Electromagnetic Biology and Medicine* 25:135–144.

Chen YB, Li J, Qi Y, Miao X, Zhou Y, Ren D, Guo GZ. 2010. The effects of electromagnetic pulses (EMP) on the bioactivity of insulin and a preliminary study of mechanism. *International Journal of Radiation Biology* 86:22–26.

Dini L, Abbio L. 2005. Bioeffects of moderate-intensity static magnetic fields on cell cultures. *Micron* 36:195–217.

Dourmashkin JT, Chang GQ, Gayles EC, Hill JO, Fried SK, Julien C, Leibowitz SF. 2005. Different forms of obesity as a function of diet composition. *International Journal of Obesity (London)* 29:1368–1378.

Feychting M. 2005. Health effects of static magnetic fields – a review of the epidemiological evidence. *Progress in Biophysics and Molecular Biology* 87:241–246.

Genius SJ. 2008. Fielding a current idea: Exploring the public health impact of electromagnetic radiation. *Public Health* 122: 113–124.

Gorczyńska E, Wegrzynowicz R. 1991. Glucose homeostasis in rats exposed to magnetic fields. *Investigative Radiology* 26:1095–1100.

Gutmann I, Wahlefeld M. 1974. L (+) lactate determination with lactate dehydrogenase and NAD. *Methods of enzymatic analysis*. New York: Academic Press. pp 1464–1472.

Havas M. 2000. Biological effects of non-ionizing electromagnetic energy: A critical review of the reports by the US National Research Council and the US National Institute of Environmental Health Sciences as they relate to the broad realm of EMF bioeffects. *Environmental Reviews* 8:173–253.

Havas M. 2008. Dirty electricity elevates blood sugar among electrically sensitive diabetics and may explain brittle diabetes. *Electromagnetic Biology and Medicine* 27:135–146.

High WB, Sikora J, Ugurbil K, Garwood M. 2000. Subchronic in vivo effects of a high static magnetic field (9.4 T) in rats. *Journal of Magnetic Resonance Imaging* 12:122–139.

- Iwasaka M, Ueno S. 1994. Enzymatic oxidation-reduction processes under magnetic fields up to 8 T (abstract). *Journal of Applied Physics* 75:7181.
- Kotani H, Kawaguchi H, Shimoaka T, Iwasaka M, Ueno S, Ozawa H, Nakamura K, Hoshi K. 2002. Strong static magnetic field stimulates bone formation to a definite orientation in vitro and in vivo. *Journal of Bone and Mineral Research* 17:1814–1821.
- Li L, Dai Y, Xia R, Chen S, Qiao D. 2005. Pulsed electric field exposure of insulin induces anti-proliferative effects on human hepatocytes. *Bioelectromagnetics* 26:639–647.
- Lo S, Russell JC, Taylor AW. 1970. Determination of glycogen in small tissue samples. *Journal of Applied Physiology* 28:234–236.
- Lombardi AM, Fabris R, Bassetto F, Serra R, Leturque A, Federspil G, Girard J, Vettor R. 1999. Hyperlactatemia reduces muscle glucose uptake and GLUT-4 mRNA while increasing (E1alpha)PDH gene expression in rat. *American Journal of Physiology* 276:E922–929.
- Metz L, Vermaelen M, Lambert K, Broca C, Sirvent P, Raynaud E, and Mercier J. 2005. Endurance training increases lactate transport in male Zucker fa/fa rats. *Biochemical and Biophysical Research Communications* 331:1338–1345.
- Miller BF, Fattor JA, Jacobs KA, Horning MA, Navazio F, Lindinger MI, Brooks GA. 2002. Lactate and glucose interactions during rest and exercise in men: Effect of exogenous lactate infusion. *The Journal of Physiology* 544:963–975.
- Navakatikyan MA, Antioch V, et al. 1994. Endocrine effects of alternating magnetic fields 50 Hz. 16th Annual Meeting Bioelectromagn. Soc., June 12–17, Copenhagen, Denmark. p. 147.
- Ócal I, Kalkan T, Günay İ. 2008. Effects of alternating magnetic field on the metabolism of the healthy and diabetic organisms. *Brazilian Archives of Biology and Technology* 51:523–530.
- Okano H. 2008. Effects of static magnetic fields in biology: Role of free radicals. *Frontiers in Bioscience* 13:6106–6125.
- Pilla AA. 2006. Mechanisms and therapeutic applications of time-varying and static magnetic fields. In: Barnes FGB, editor. *Handbook of biological effects of electromagnetic fields*. 3rd ed. Boca Raton, FL: CRC Press. pp 351–412.
- Pujol A, Lefaucheur L, Ecolan P, Picon L, Penicaud L. 1993. Fiber type composition and enzyme activities of muscles in two models of obese rats. *Comparative Biochemistry and Physiology B* 106:269–272.
- Py G, Lambert K, Milhavel O, Eydoux N, Prefaut C, Mercier J. 2002. Effects of streptozotocin-induced diabetes on markers of skeletal muscle metabolism and monocarboxylate transporter 1 to monocarboxylate transporter 4 transporters. *Metabolism* 51:807–813.
- Py G, Lambert K, Perez-Martin A, Raynaud E, Prefaut C, Mercier J. 2001. Impaired sarcolemmal vesicle lactate uptake and skeletal muscle MCT1 and MCT4 expression in obese Zucker rats. *American Journal of Physiology Endocrinology and Metabolism* 281:E1 308–1315.
- Repacholi MH, Greenebaum B. 1999. Interaction of static and extremely low frequency electric and magnetic fields with living systems: Health effects and research needs. *Bioelectromagnetics* 20:133–160.
- Rosen AD. 2003a. Effect of a 125 mT static magnetic field on the kinetics of voltage activated Na⁺ channels in GH3 cells. *Bioelectromagnetics* 24:517–523.
- Rosen AD. 2003b. Mechanism of action of moderate-intensity static magnetic fields on biological systems. *Cell Biochemistry and Biophysics* 39:163–173.
- Savage DB, Petersen KF, Shulman GI. 2007. Disordered lipid metabolism and the pathogenesis of insulin resistance. *Environmental Reviews* 87:507–520.
- Shibuya I, Honda H, Maruo B. 1967. Simplified colorimetry without incineration of phosphorus in phosphatides. *Agricultural and Biological Chemistry* 31:111–114.
- Srere P. 1969. Citrate synthase. *Methods in Enzymology* 3–5.
- Ueno S, Shigemitsu T. 2007. Biological effects of static magnetic fields. In: Barnes FS, Greenebaum B, editors. *Handbook of biological effects of electromagnetic fields: Bioengineering and biophysical aspects of electromagnetic fields*. 3rd ed. Boca Raton, FL: CRC Press.
- Vettor R, Lombardi AM, Fabris R, Pagano C, Cusin I, Rohner-Jeanrenaud F, Federspil G, Jeanrenaud B. 1997. Lactate infusion in anesthetized rats produces insulin resistance in heart and skeletal muscles. *Metabolism* 46:684–690.
- Vettor R, Lombardi AM, Fabris R, Serra R, Pagano C, Macor C, Federspil G. 2000. Substrate competition and insulin action in animal models. *International Journal of Obesity and Related Metabolic Disorders* 24:S22–24.
- Wang Z, Sarje A, Che PL, Yarema KJ. 2009. Moderate strength (0.23–0.28 T) static magnetic fields (SMF) modulate signaling and differentiation in human embryonic cells. *BMC Genomics* 10:356–378.
- Weintraub MI, Cole SP. 2004. Pulsed magnetic field therapy in refractory neuropathic pain secondary to peripheral neuropathy: Electrodiagnostic parameters – pilot study. *Neurorehabilitation and Neural Repair* 18:42–46.
- Weintraub MI, Wolfe GI, Barohn RA, Cole SP, Parry GJ, Hayat G, Cohen JA, Page JC, Bromberg MB, Schwartz SL. 2003. Static magnetic field therapy for symptomatic diabetic neuropathy: A randomized, double-blind, placebo-controlled trial. *Archives of Physical Medicine and Rehabilitation* 84:736–746.
- World Health Organisation (WHO). 2006. *Environmental Health Criteria 232. Static fields*. Geneva, Switzerland: WHO.
- Zhang QM, Tokiwa M, Doi T, Nakahara T, Chang PW, Nakamura N, Hori M, Miyakoshi J, Yonei S. 2003. Strong static magnetic field and the induction of mutations through elevated production of reactive oxygen species in *Escherichia coli* soxR. *International Journal of Radiation Biology* 79:281–286.